



BR 31a · Quarter-turn actuator

Version DAP / SRP 15 · Technical data and spare parts



Applications

Single-acting or double-acting piston actuators for butterfly valves, ball valves and other final control elements with rotary closure members. Particularly suitable for high process requirements in chemical plants:

- Opening angle 90°
- Temperatures -40°C to +80°C



Dimensions of quarter-turn actuator

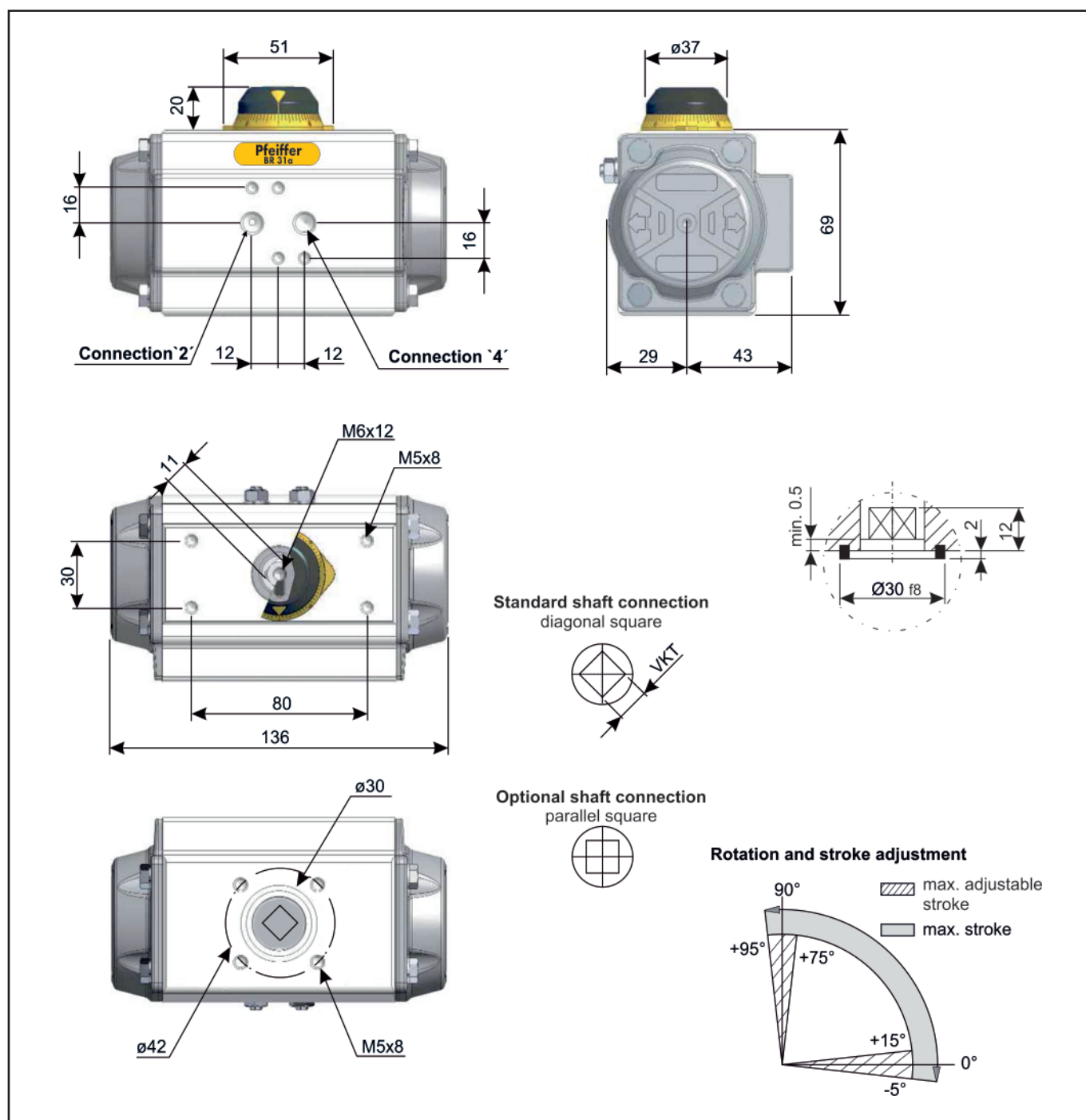

Fig. 2: Dimensional drawing

Table 1: Connection dimensions / Connections

ISO 5211	Flange	F04
	Square (diagonal)	11mm
VDI/VDE 3845	Air connection	24x32mm + 2x G1/8"
	Fixing level 1	AA1 (80x30x20mm)

Technical Data

Table 2: Torques for double and single acting quarter-turn actuators

Type	Torque double and single acting in Nm																				Spring stroke		Weight in kg		
	2.5		3		3.5		4		4.2		4.5		5		5.5		6		7		8			90°	0°
	0°	90°	0°	90°	0°	90°	0°	90°	0°	90°	0°	90°	0°	90°	0°	90°	0°	90°	0°	90°					
DAP	8.3		10		11.6		13.3		14		15		16.6		18.3		19.9		23.3		26.6		-		1.1
																						Start	End		
SRP 2,5	5.0	3.0	7.0	4.7	8.0	6.3	10.0	8.0	10.7	8.7	11.7	9.6	13.3	11.3	14.8	13.3	16.5	15.0	19.8	18.3	23.1	21.6	5.3	3.3	1.12
SRP 3	4.0	1.9	6.0	3.6	7.7	5.3	9.3	6.9	10.0	7.6	11.0	8.6	12.7	10.2	14.3	11.9	15.9	14.1	19.2	17.4	22.5	20.7	6.4	4	1.14
SRP 3,5	3.6	1.5	5.3	2.5	7.0	4.2	8.7	5.8	9.4	6.6	10.3	7.5	12.0	9.2	13.7	10.8	15.3	12.5	18.5	16.4	21.8	19.7	7.4	4.6	1.16
SRP 4	2.9	0.5	4.6	2.2	6.3	3.0	8.0	5.0	8.7	5.5	9.7	6.4	11.3	8.1	13.0	9.8	14.7	11.4	18.0	14.7	21.1	18.7	8.5	5.3	1.18
SRP 4,5	2.2		3.9	1.2	5.5	2.8	7.3	3.7	8.1	4.4	9.0	5.4	10.7	7.0	12.3	8.7	14.0	10.0	17.3	13.7	20.6	17.0	9.6	5.9	1.2
SRP 5	1.6		3.3	0.3	4.9	1.9	6.6	3.6	7.2	4.2	8.4	4.3	10.0	6.0	11.7	7.6	13.3	9.3	16.7	12.6	20.0	16.0	10.6	6.6	1.22
SRP 5,5	0.9		2.6		4.2	0.9	5.9	2.6	6.5	3.2	7.5	4.2	9.4	4.9	11.0	6.6	13.0	8.2	16.0	11.6	19.3	14.9	11.7	7.3	1.24
SRP 6	0.2		1.9		3.5		5.2	1.6	5.8	2.2	6.8	3.2	8.5	4.9	10.4	6.0	12.0	7.2	15.3	10.5	18.7	13.8	12.8	7.9	1.26

Table 3: Specially technical data

Type	Pressure max. in bar	Rotation	Screw stroke adjustment	Chamber Ø in mm	Air volume in Litre		Moving time in Sec. ¹⁾		Operating temperature in °C ²⁾		
					Open	Close	Open	Close	STD (Standard)	HT (High temp.)	SLT (Low temp.)
DAP	8	90° -5°/+15°	for 1° 1/6 rotation	50	0.09	0.15	0.20	0.25	-40 bis +80	-15 bis +150	-55 bis +80
SRP							0.25	0.30			

¹⁾ The above indicated moving time of the actuator is obtained under the following test conditions: (1) room temperature, (2) actuator stroke 90°, (3) solenoid valve with Ø4mm and flow capacity Qn 400 L/min., (4) inside pipe Ø8mm, (5) medium clean air, (6) air supply pressure 5,5 bar (79,75 Psi), (7) actuator without external resistance load.

It has to be expected, e.g. for field applications, when one or more of the above parameters are different, the moving time will be different.

²⁾ For HT (high temperature) and SLT (low temperature) applications a special grease is needed. Please contact PFEIFFER.

Table 4: Air consumption

Type	Air consumption in Litre / Switching cycle ³⁾									
Pressure	2.5	3	3.5	4	4.5	5	5.5	6	7	8
DAP	0.84	0.96	1.08	1.20	1.32	1.44	1.56	1.68	1.92	2.16
SRP	0.32	0.36	0.41	0.45	0.50	0.54	0.59	0.63	0.72	0.81

³⁾ A switching cycle is the movement from 0° to 90° + 90° to 0°

Operating Medium:

The operating medium must be free of dust and oil. The maximum particle size must not exceed 30µ. (ISO 8573 Part1, Class5). In order to prevent water condensation and/or solidification (ice when actuator works below 0°C), the operating medium must have a dew point equal to -20°C or at least 10°C below the ambient temperature (ISO 8573 Part1, Class3).

Parts list for actuator DAP/SRP 15

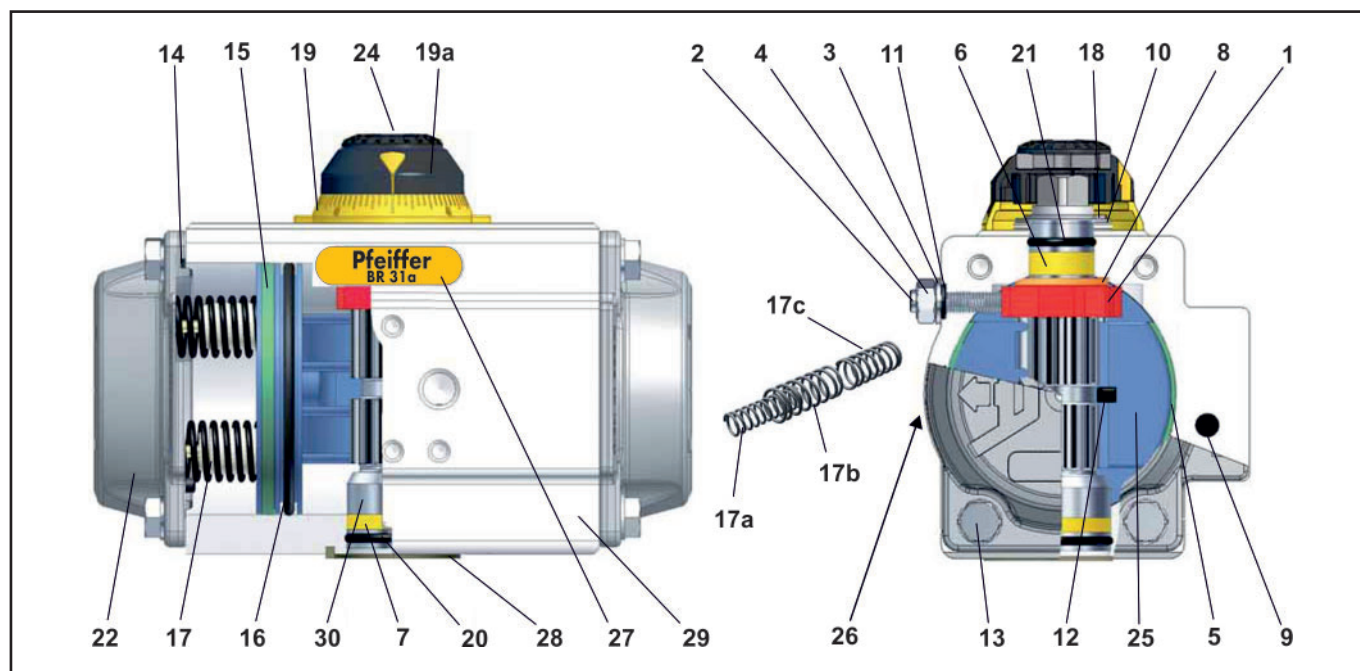

Fig. 3: Quarter-turn actuator BR 31a, Type SRP 15

Table 5: Parts and spare parts list

Item	Qty.	Description	Material	Abrasion package for SRP/DAP 15
1	1	Octi-cam	Stainless steel	STD = 43718v HT = 45444v SLT = 48021v
2	2	Stop cap screw	Stainless steel	
3	2	Washer	Stainless steel	
4	2	Stop screw	Stainless steel	
5 ¹⁾	2	Piston guide bearing	PA46	
6 ¹⁾	1	Pinion top bearing	PA46	
7 ¹⁾	1	Pinion bottom bearing	PA46	
8 ¹⁾	2	Pinion thrust bearing	PA46	
9 ^{1) 2) 3)}	2	Plug	Silicone	
10	1	Thrust washer	Stainless steel	
11 ^{1) 2) 3)}	2	O-ring	M-NBR	
12	2	Piston guide	PA66+GF	
13	16	Cap Screw	Stainless steel	
14 ^{1) 2) 3)}	2	O-ring	M-NBR	
15 ^{1) 2)}	2	Piston head bearing	POM	
16 ^{1) 2) 3)}	2	O-ring	M-NBR	
17a ⁴⁾	2 to 6	Spring	SiCr Spring alloy Steel epoxy coated	
17b ⁴⁾		Spring		
17c ⁴⁾		Spring		
18	1	Spring clip	Spring steel, ENP	
19	1	Graduated ring	PA66+GF(+CB)	
19a	1	Position indicator	PA66+GF+CB	
20 ^{1) 2) 3)}	1	O-ring	M-NBR	
21 ^{1) 2) 3)}	1	O-ring	M-NBR	
22	1	End cap	Pressure die cast aluminium alloy, anodized and coated	
24	1	Cap screw	PA66+GF+CB	
25	2	Piston	Pressure die cast aluminium alloy, anodized	
26	1	Identification label	Polyester-Silver	
27	2	Plate	Polyester	
28	1	Spigot	Extruded aluminium alloy, anodized	
29	1	Body	Extruded aluminium alloy, coated	
30	1	Drive shaft	Steel, ENP	

¹⁾ Included in the abrasion package (STD), ²⁾ Included in the high temperature kit (HT), ³⁾ Included in the low temperature set (SLT)
⁴⁾ per side