



Storage of VETEC products

EB005.045 EN

Chap. 4 (03-01)

Translation of original instructions

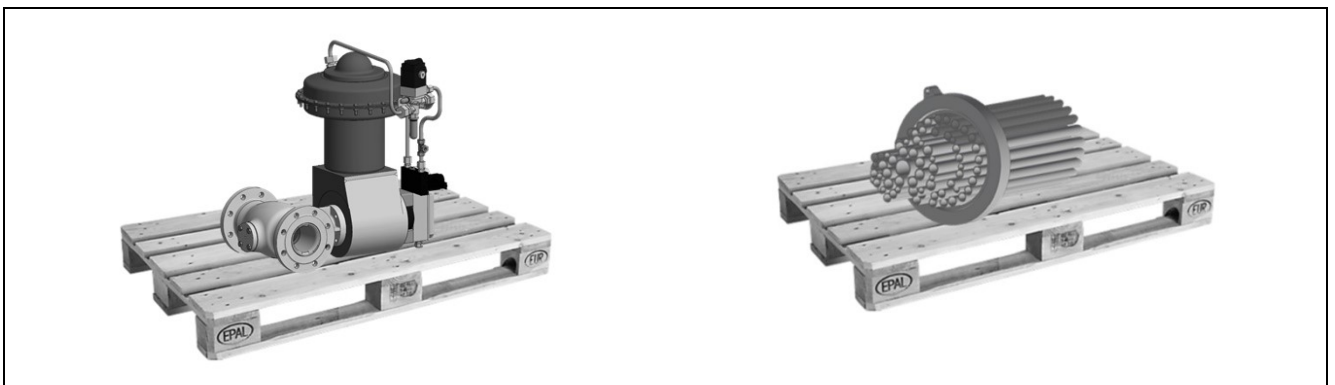

Rotary Plug Valves Series 62, 72, 73, 82 with Actuators e.g. Type R, M
Components (e.g., silencer), Spare Parts, Elastomers

Note on these Instructions

This document is an excerpt (chap. 1) from the mounting and operating instructions of the device. The division of the complete document corresponds to the categories of the guideline VDI 2770.

The instructions in this document cover only a small part of the manufacturer's information for this device.

For the safe and proper use of the device, all persons handling the product must have read and understood also the following sections of the mounting and operating instructions before starting any work: The chapters describing the activity to be carried out

The images shown in these instructions are for illustration purposes only. The actual product may vary.

- ➔ For the safe and proper use of these instructions, read them carefully and keep them for later reference.
- ➔ We accept no responsibility for damage and operational faults caused by failure to comply with these instructions.
- ➔ If you have any questions beyond the contents of this document, please refer to the complete document of the mounting and operating instructions or contact VETEC after-sales.

Definition of signal words

DANGER

Hazardous situations which, if not avoided, will result in death or serious injury

WARNING

Hazardous situations which, if not avoided, could result in death or serious injury

NOTICE

Property damage message or malfunction

Note

Additional information

Tip

Recommended action

CONTENT

1. Safety instructions and measures	4
2. Storage instructions	5
3. Special storage instructions for elastomers (e.g., actuator diaphragm, O-rings).....	6
4. Positioning of the control valves during storage.....	6
4.1. Rotary plug valves with pneumatic actuators (e.g. Type R, M)	6
4.2. Rotary plug valves with electrical actuators (described with an example)	7

1. Safety instructions and measures

Scope of documentation

This document contains instructions and information on the storage conditions and storage times of control valves, spare parts and components.

The following documents apply in addition to this manual:

- Mounting and operating instructions of the valve, actuator, and accessories, components (e.g., silencer)

DANGER

Risk due to stored loads falling/tipping!

- Observe the centre of gravity of the control valve or the separate components (e.g. silencer).
 - Secure control valves/components against tipping and falling in storage position.
-

WARNING

Risk of injury due to incorrect lifting without the use of lifting equipment!

Lifting the control valve without the use of lifting equipment may lead to injuries (back injury in particular) depending on the weight of the control valve.

- Observe the occupational health and safety regulations valid in the country of use.
 - The selection of the appropriate lifting method is the responsibility of the plant operator.
-

NOTICE

Risk of valve damage due to improper storage!

Observe the storage instructions.

- Avoid long storage times (more than 3 months).
 - Inspect the control valve and storage conditions regularly.
 - Observe recommended storage position of the device and components.
 - If necessary, observe the support of the control valve.
 - The associated documentation of the actuator and accessories is binding for the handling of the control valve.
-

NOTICE

Corrosion risk due to incorrect storage!

- Store in a well-ventilated, dry room.
 - Protect against soil moisture by storing in shelving or on a wooden grid.
 - Cover to protect against dust and dirt.
-

NOTICE

Risk of device/components damage due to improper force impact!

Device, attachments and components can be damaged by improper use of force.

- Not suitable as a stepping area.
 - Do not exert any improper force on the device (valve, actuator, attachments) and components.
 - Do not store the control valve on the attachments, control lines and actuator. Observe the positioning of the device and components during storage.
 - Do not expose control valves with internal parts e.g., made of ceramics, tungsten carbide (hard metal) to sudden mechanical and thermal loads (shocks).
-

! NOTICE**Risk of damage to the valve with actuator type MN due to improper lifting, transport, storage and installation!**

The actuator type MN has an internal, centrally located spring that is not on bearings.

→ Transport, lift, store and install the valve only with the shaft horizontal (actuator pointing upwards). See chap.5.

! NOTICE

For longer storage periods of more than 3 month, VETEC recommends checking the function of the valves at regular intervals.

Before installing the control valve in the pipeline, an inspection is required, and maintenance must be carried out if necessary.

i Note

A functional test has to be carried out before installing the valve in the pipeline, regardless of the storage time.

i Note

Attachments (e.g., positioner etc.) may only be stored under certain conditions, refer to the associated documentation.

2. Storage instructions

- Store control valves, spare parts, and components in their original, unopened packaging to protect them from damage, e.g., shocks, impacts, dirt, etc.
- Do not stack control valves (valves, actuators, components etc.) during storage.
- Do not place any objects on the control valve.
- All pneumatic and electrical connections are secured and sealed with plastic plugs to prevent the ingress of dirt/moisture. These plastic plugs must only be removed immediately before commissioning.
- Make sure that the flange covers on the valve inlet and outlet are firmly seated and are only removed immediately before installation.
- Do not damage corrosion protection (paint, surface coatings). Repair any damage immediately (priming and repainting).
- Make sure that the ambient air is free of acids or other corrosive and aggressive media.
- Store control valves in a dry place and protect them from climatic influences: avoid rain, snow, humidity, or direct sunlight etc. before installation.
- Store the control valves and components at a relative humidity of less than 75 %. In damp spaces, prevent condensation. If necessary, use a drying agent or heating.
- Depending on the product, the ambient temperature must be within the specified temperature range (see technical product specification). We recommended storage temperature of 15 °C.
- Do not store electronic devices such as positioners at a room temperature above 25 °C and near heat sources such as radiators, heating pipes, etc. Storage and preservation of electronic devices may only be carried out in accordance with the manufacturer's instructions.
- Covers of attachments, such as positioners or limit switches, must be correctly closed and tightened.

Supplementary storage instructions for control valves with cleaned parts (e.g., for oxygen service)

- Check regularly that the packaging labeling (e.g., oxygen service, cleaned parts etc.) is legible and that the packaging is intact. Renew any labeling that has become illegible.
- When the packaging is damaged, the device or components may possibly be contaminated. Contact VETEC After-sales Service before using the device.
- Only remove control valves and components from their packaging prior to immediate use/installation.
- Store valves and components in a separate area which is marked accordingly.
- Store valves and components in a dry and clean environment.

3. Special storage instructions for elastomers (e.g., actuator diaphragm, O-rings)

i Note

When removing the products from the warehouse, the following checks must be carried out:

- Permanent deformation (folds, flat spots)
- Mechanical damage (cuts, cracks, "abraded" spots, delamination)
- Surface cracks
- Changes on the surface (hardening, softening, stickiness)

- Keep all original designation together with or on the parts until final use.
- To keep elastomers in shape and to prevent cracking, do not bend them or hang them up. Deformation or tensile stresses are not allowed.
- Make sure that the ambient air is free of acids or other corrosive and aggressive media.
- Store elastomers separately from lubricants, chemicals, solutions, and fuels.
- Packaging material must not emit substances that damage elastomers. PVC is not recommended as packaging material. We recommended PE bags with a minimum thickness of 0.075 mm.
- Elastomers are damaged by ultraviolet light and ozone (cracking). Pack the elastomers in black plastic bags to protect from light/sunlight.
- Store elastomers in a dry and clean place. Avoid condensation.
- Do not store elastomers near sources of heat such as radiators, heating pipes, etc. Do not store elastomers at room temperature above 25 °C.
- The storage temperature must be within the specified temperature range depending on the product (see technical product specification). We recommended storage temperature of 15 °C.

4. Positioning of the control valves during storage

4.1. Rotary plug valves with pneumatic actuators (e.g. Type R, M)

→ VETEC recommends storing the control valves with M-actuator with horizontal shaft and with R-actuator with vertical (upright) shaft, see Fig.1 to 4.

Secure the valve in the stored position against slipping or tipping over.

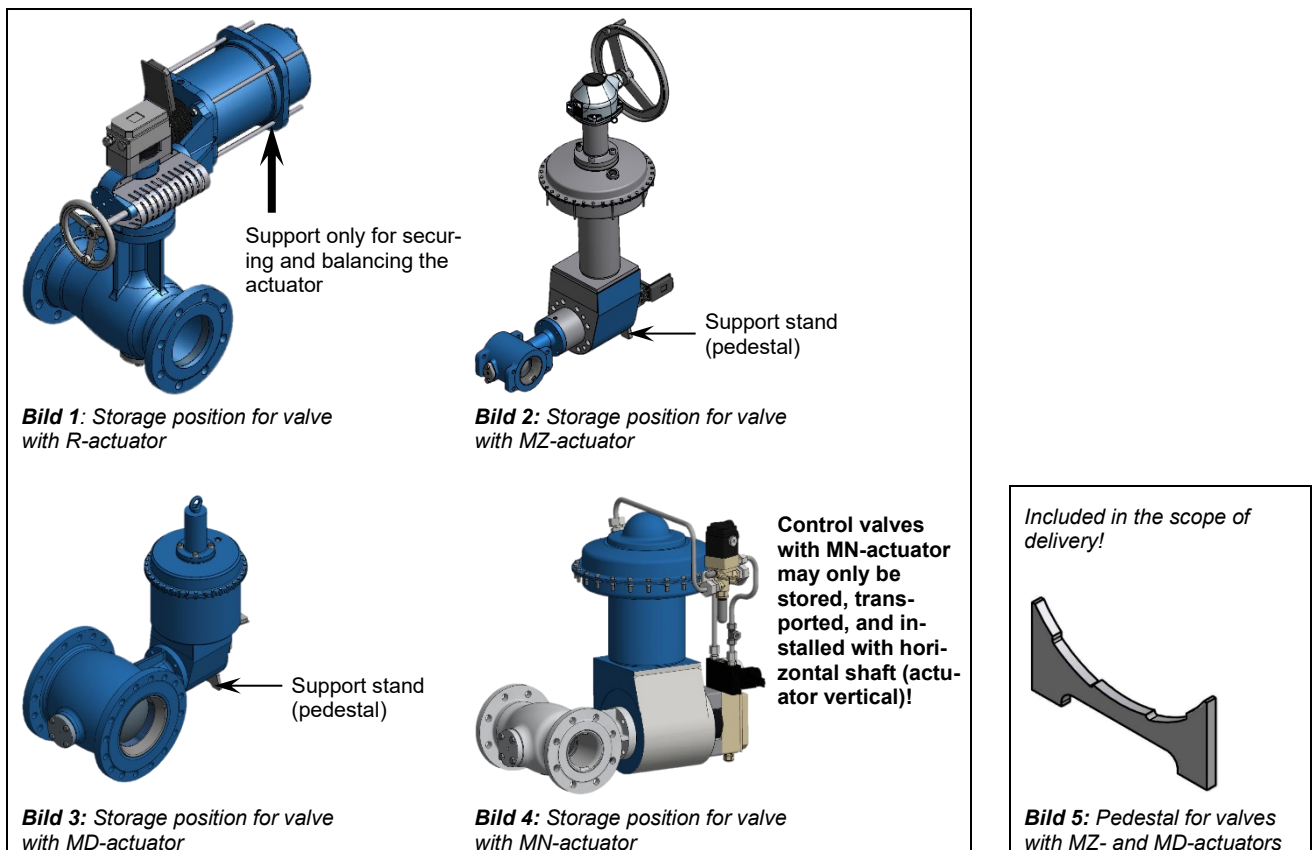

4.2. Rotary plug valves with electrical actuators (described with an example)

HINWEIS

Damage to the actuator due to improper storage of the device!

Observe the storage instructions of the actuator.

→ The associated documentation of the actuator manufacturer is binding for the handling the device.

→ If necessary, observe the support of the actuator.

▪ Positioning of the control valves during storage

i Note

According to the manufacturer's operating instructions, two situations must be considered:

- If oil is used in the gearbox of the actuator, store, transport and install the control valve vertically (upright). See fig.6.

- If grease is used in the gear box, the actuator can be operated in any mounting position.

→ Store control valve with vertical shaft (upright).

→ Support the actuator (only for securing/balancing the actuator). Support area according to installation and operating instructions of the actuator.

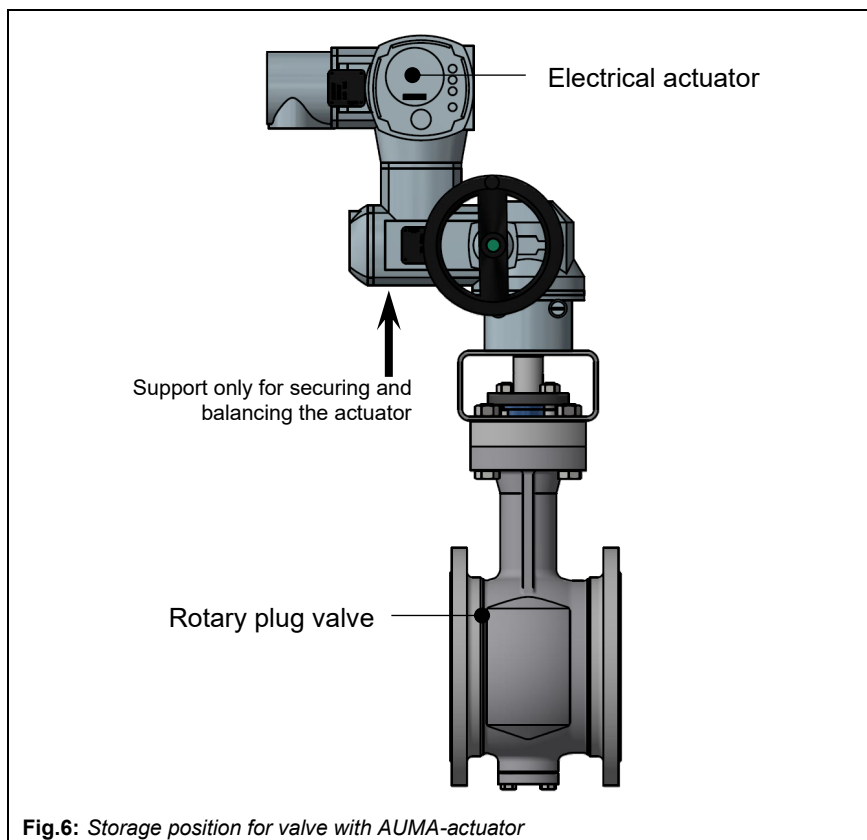

Control valves with AUMA actuators and oil in the gearbox may only be stored, transported, and installed with vertical shaft (upright), with the actuator on top!

Fig.6: Storage position for valve with AUMA-actuator

- Positioning of the control valves for short-term storage (e.g., for transport) → only for actuators with grease in the gearbox

i Note

For longer storage periods see fig.6.

- Store control valve with horizontal shaft.
- Support the control valve on the bracket (load bearing support).
- Support the actuator (non-load bearing support, only for securing/balancing the actuator). Support area according to installation and operating instructions of the actuator.

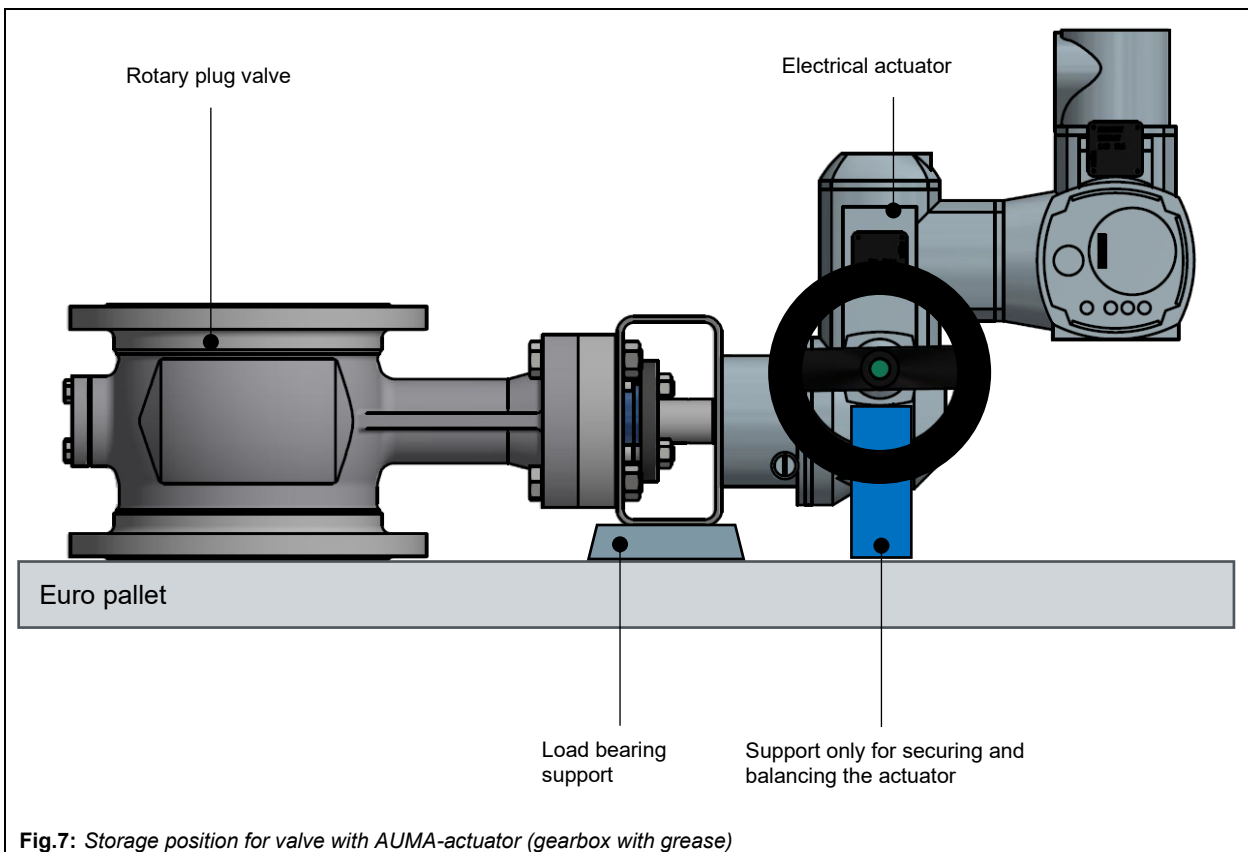

Fig.7: Storage position for valve with AUMA-actuator (gearbox with grease)



VETEC Ventiltechnik GmbH

Siemensstrasse 12 · 67346 Speyer · Germany

Phone: +49 6232 6412-0 · Fax: +49 6232 42479

E-mail: sales-vetec-de@samsongroup.com · Internet: www.vetec.samsongroup.com