

MOUNTING AND OPERATING INSTRUCTIONS



EB 2133 EN

Translation of original instructions



Self-operated Temperature Regulators

Type 9 Temperature Regulator

Edition July 2024



Note on these mounting and operating instructions

These mounting and operating instructions assist you in mounting and operating the device safely. The instructions are binding for handling SAMSON devices. The images shown in these instructions are for illustration purposes only. The actual product may vary.

- For the safe and proper use of these instructions, read them carefully and keep them for later reference.
- If you have any questions about these instructions, contact SAMSON's After-sales Service (aftersaleservice@samsongroup.com).



Documents relating to the device, such as the mounting and operating instructions, are available on our website at www.samsongroup.com > **Downloads > Documentation.**



Testing according to DIN EN

The Types 2231 to 2234 Control Thermostats have been tested together with valves by the German technical surveillance association TÜV in accordance with DIN EN 14597. The register number is available on request.

Definition of signal words

DANGER

Hazardous situations which, if not avoided, will result in death or serious injury

WARNING

Hazardous situations which, if not avoided, could result in death or serious injury

NOTICE

Property damage message or malfunction

Note

Additional information

Tip

Recommended action

1	General safety instructions	4
2	Process medium and scope of application	5
2.1	Transportation and storage	5
3	Design and principle of operation	5
3.1	Excess temperature indication	8
4	Installation	8
4.1	Installing the valve.....	10
4.1.1	Strainer.....	10
4.1.2	Additional components.....	10
4.2	Installing control thermostats	11
4.2.1	Types 2231 and 2232 (bulb sensor).....	12
4.2.2	Type 2234 (air sensor)	13
4.2.3	Capillary tube	14
4.3	Operating element.....	14
4.4	Dynamic behavior of control thermostats.....	14
5	Operation	15
5.1	Start-up.....	15
5.2	Set point adjustment.....	15
5.2.1	Correcting the set point dial	16
6	Mounting additional parts	16
6.1	Extension piece.....	16
6.2	Intermediate piece.....	17
6.3	Double adapter	17
7	Maintenance – Replacing parts	18
7.1	Troubleshooting	19
8	Markings on the device	22
8.1	Nameplates.....	22
8.2	Location of the nameplates	23
8.3	Material identification number	23
8.3.1	Type 2119 Valve.....	23
8.3.2	Types 2231 to 2234 Control Thermostat	23
9	Disposal	24
10	After-sales service	24
11	Dimensions and weights	25
11.1	Accessories	26



1 General safety instructions

- The device must be mounted, started up or serviced by fully trained and qualified personnel only; the accepted industry codes and practices are to be observed. Make sure employees or third parties are not exposed to any danger.
- All safety instructions and warnings given in these mounting and operating instructions, particularly those concerning installation, start-up, and maintenance, must be strictly observed.
- According to these mounting and operating instructions, trained personnel refers to individuals who are able to judge the work they are assigned to and recognize possible dangers due to their specialized training, their knowledge and experience as well as their knowledge of the applicable standards.
- The devices comply with the requirements of the European Pressure Equipment Directive 2014/68/EU. Devices with a CE marking have an EU declaration of conformity, which includes information about the applied conformity assessment procedure. This EU declaration of conformity can be provided on request.
- To ensure appropriate use, only use the device in applications where the operating pressure and temperatures do not exceed the specifications used for sizing the device at the ordering stage.
- The manufacturer does not assume any responsibility for damage caused by external forces or any other external factors.
- Any hazards that could be caused in the temperature regulator by the process medium, operating pressure or by moving parts are to be prevented by taking appropriate precautions.
- Proper transport, storage, installation, operation and maintenance are assumed.

Note: Non-electric valve versions whose bodies are not lined with an insulating material coating do not have their own potential ignition source according to the hazard assessment stipulated in Clause 5.2 of ISO 80079-36, even in the rare incident of an operating fault. Therefore, such valve versions do not fall within the scope of Directive 2014/34/EU (ATEX). For connection to the equipotential bonding system, observe the requirements specified in Clause 6.4 of EN 60079-14 (VDE 0165-1).

2 Process medium and scope of application

Temperature regulator with three-way valve for mixing and diverting service. For plants that are heated or cooled using liquids. With Type 2231 to Type 2234 Control Thermostats for set points from -10 to $+250$ °C. Nominal sizes DN 15 to 150. Pressure rating PN 16 to 40. Suitable for temperatures up to 350 °C.

2.1 Transportation and storage

The temperature regulators must be carefully handled, transported and stored. Protect the regulator against adverse influences, such as dirt, moisture, frost or heat, during storage and transportation before being installed.

When temperature regulators are too heavy to be lifted by hand, fasten the lifting sling to a suitable place on the valve body.

⚠ WARNING

Incorrectly attached lifting slings or rigging equipment will lead to injury or property damage due to valve falling.

➔ *Securely fasten slings and rigging equipment to the valve body and secure against slipping.*

3 Design and principle of operation

See Fig. 2.

The temperature regulators consist of the valve (1), control thermostat with temperature sensor (16) and capillary tube (10).

The valve (1) mainly consists of the body with two seats (2), plugs (3) and the plug stem (5). Depending on the application, different control thermostats can be attached to the valve. The control thermostat comprises the temperature sensor (16), set point adjuster (11), capillary tube (10) and operating element (8).

The temperature regulators operate according to the liquid expansion principle. The temperature sensor (16) is filled with an expansion liquid. The temperature-dependent change in volume of this liquid causes the double plug (3) to move over the capillary tube (10) and the operating element (8), which is connected to the valve by a coupling nut (7). For example, when the temperature at the sensor (16) rises, the liquid contained in the sensor expands and causes the pin of the operating element to move upwards. This movement is transmitted to the plug stem (5). As a result, the double plug (3) in the valve body is pushed upwards against the force of the return spring (5.1). The plug reduces the inflow at port B at the top seat (2) and increases the inflow at port A at the bottom seat (mixing valve). The Type 9 Temperature Regulator in DN 32 and larger is balanced by a metal bellows (4.1).

Design and principle of operation

The pressure at port A is applied to the bottom side of the double plug and transmitted onto the inside of the metal bellows through the plug stem guide.

The pressure at port B is applied to the top of the double plug and transmitted to the outside of the metal bellows through the hollow plug stem (5). As a result, the forces acting on the valve plug are balanced out and the valve is fully balanced. Consequently, any pressure changes in the process medium do not affect the position of the valve plug.

When used as a mixing valve, port B closes when the temperature at the sensor rises. In diverting valves, port A closes when the temperature at the sensor rises.

The set point can be adjusted using a key (11). By turning the key, a spindle moves the piston (15) up or down. The resulting change in volume in the sensor (16) causes the valve

plug to travel according to the adjusted set point within a higher or lower temperature range measured by the sensor.

Legend for Fig. 2

Valve

- 1 Valve body
- 2 Seat
- 3 Plug
- 4 Bottom section
- 4.1 Balancing bellows
- 5 Plug stem
- 5.1 Spring
- 6 Threaded connection for operating element

Control thermostat

- 7 Coupling nut
- 8 Operating element
- 9 Pin of operating element
- 10 Capillary tube
- 11 Set point adjustment key
- 12 Set point dial
- 13 Coupling nut
- 14 Double nipple
- 15 Piston (inside)
- 16 Temperature sensor

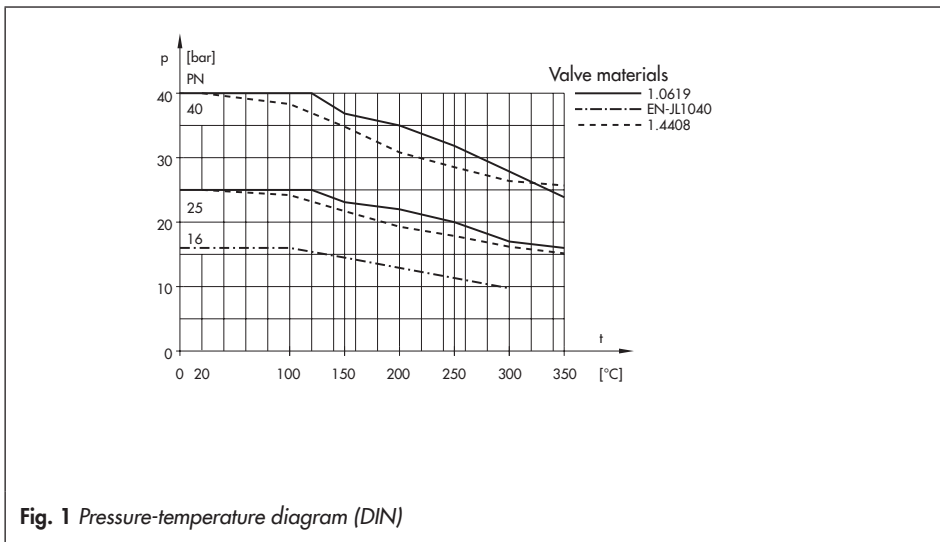

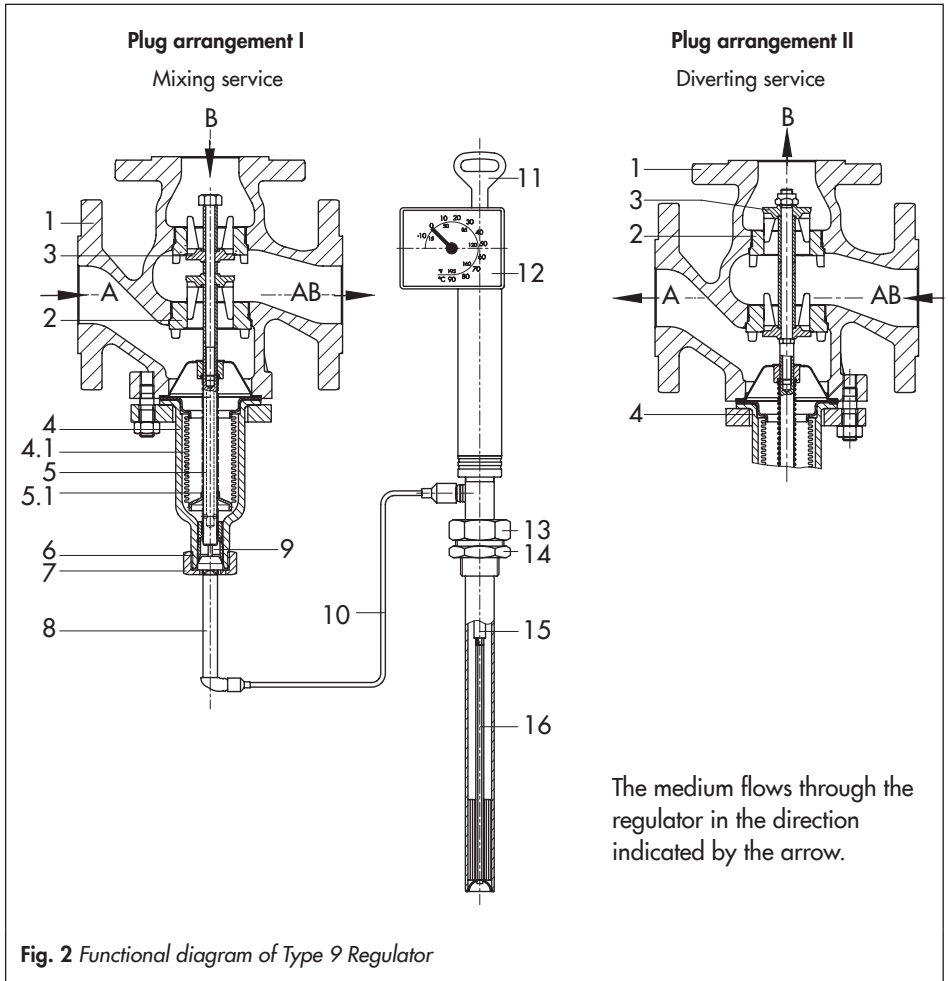

3.1 Excess temperature indication

If the temperature at the sensor exceeds 100 K, the inside piston (15) with the attached stem is pushed out of the housing of the set point dial (10).

If the stem does not move back after the temperature had dropped again, the operating element (8) has been damaged due to excessively high temperature. Send the control thermostat back to SAMSON for repair.

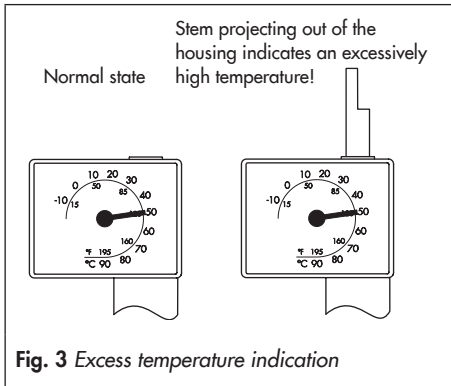

4 Installation

Installation instructions provided by the manufacturer of the plant must be observed.

If necessary, contact the manufacturer or supplier.

The following points must be observed during installation:

- Only open the shut-off valves in the plant after the control thermostat has been mounted on the valve.
- The temperature regulator is first sealed when the operating element is fastened onto the bottom section.

⚠ WARNING

Risk of injury due to process medium escaping possibly under pressure.

➔ *Screw the operating element of the control thermostat tightly to the valve to seal the body connection. Afterwards, open the shut-off valves!*

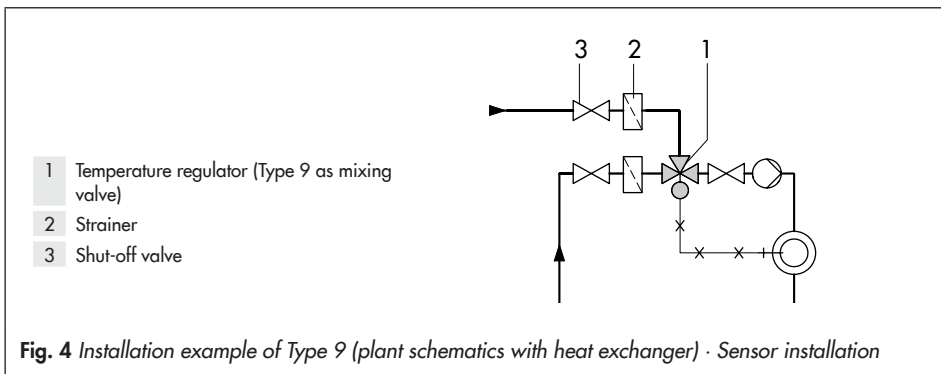

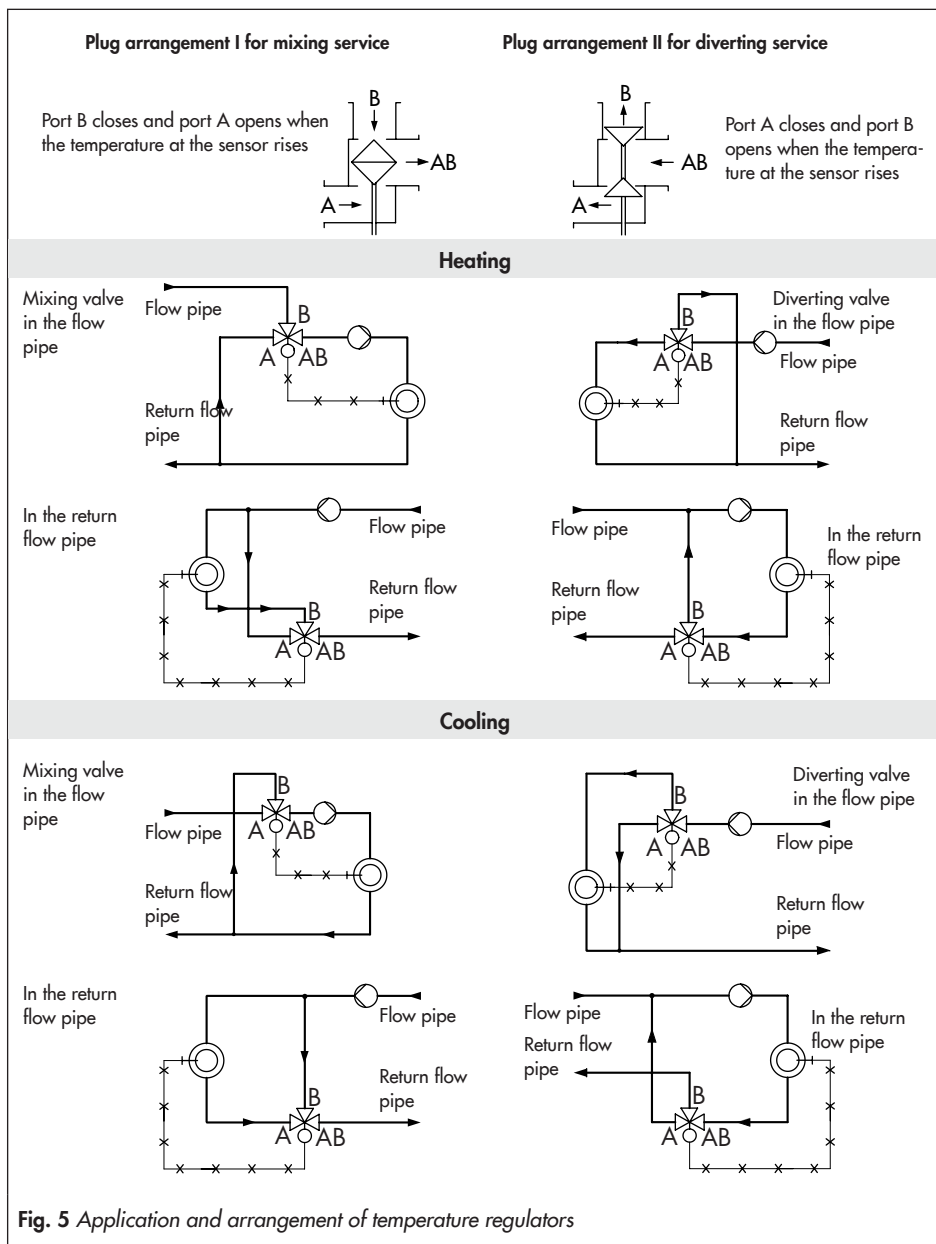

Fig. 5 Application and arrangement of temperature regulators

4.1 Installing the valve

Choose a place of installation that allows you to freely access the regulator even after the entire plant has been completed.

i Note

Do **not** install the temperature regulator between a pressure reducing valve and its control line connection.

Flush the pipeline thoroughly before installing the temperature regulator. Install a strainer (see Chapter 4.1.1) upstream of the regulator to prevent any sealing parts, weld spatter and other impurities carried along by the process medium impairing the proper functioning of the valve, above all the tight shut-off.

i Note

Install the valve in a horizontal pipeline with the operating element connection suspended downward.

- Install the valve free of stress and with the least amount of vibrations as possible. If necessary, support the pipelines near the connections.
- When regulating steam, install upstream steam pipes with a slight upward slope and downstream steam pipes with a slight downward slope to prevent excessive amounts of condensed water from collecting.

i NOTICE

Malfunction and damage due to adverse weather conditions (temperature, humidity).
Do not install the temperature regulator outdoors or in rooms prone to frost. If such a location cannot be avoided, protect the regulator against freezing up if the process medium flowing through the valve can freeze up. Either heat the regulator or remove it from the plant and completely drain the residual medium.

4.1.1 Strainer

Install a strainer (e.g. SAMSON Type 2 NI) upstream of the temperature regulator.

- The flow of direction must correspond with the direction indicated by the arrow on the valve body.
- The filter element must be installed to hang downwards or sideways for applications with steam.

i Tip

Remember to leave enough space to remove the filter element for cleaning.

4.1.2 Additional components

SAMSON recommends installing a hand-operated shut-off valve both upstream of the strainer and downstream of the temperature regulator. This allows the plant to be shut down for cleaning and maintenance, and when the plant is not used for longer periods of time.

Install a thermometer near the sensor to check the adjusted set point.

4.2 Installing control thermostats

See Fig. 2.

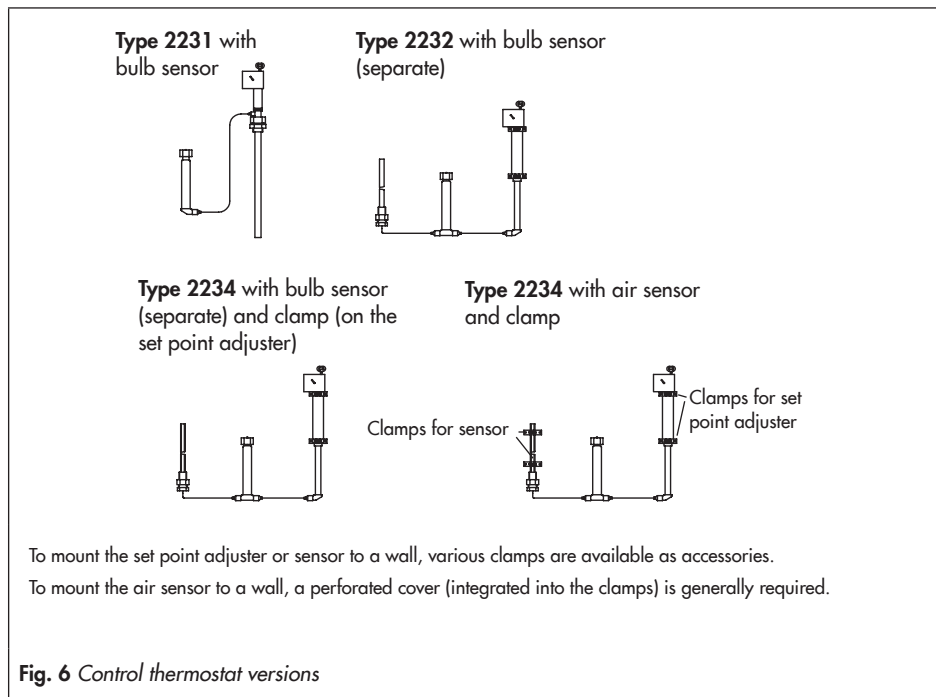

Size specifications for SAMSON control thermostats

Table 1: Assignment of control thermostat sizes and valves

Size	Control thermostat to fit:	Types 2111/2422/2119 Valves
150	Types 2231, 2232, 2234	DN 15 to 150
	Type 2213 for STM	
	Type 2212 for STL	DN 65 to 150

4.2.1 Types 2231 and 2232 (bulb sensor)

Bulb sensors are used to measure the temperature of liquids. They are designed for installation in pipelines, heat exchangers, boilers, baths, tanks etc.

i Note

The entire length of the sensor must be immersed in the process medium. Observe the permissible mounting position as illustrated in Fig. 7.

! NOTICE

Process medium leakage due to missing seal at the sensor.

The use of a thermowell is mandatory in combination with a Type 2232 Control Thermostat with clamping gland.

Installation recommendations

Select the place of installation ensuring that the sensor is installed as close as possible to the heat source, but avoid exposing it to overheating.

When mounted in a boiler, install the sensor in the top third of the boiler.

When mounted in a counterflow heat exchanger, install the sensor in a pipe elbow, directly behind the pipe end socket piece.

In plants with only temporary heat consumption, install the temperature sensor so that it is totally immersed in the heat exchanger. If this is not possible, a circulating pipe must be provided to allow the sensor to always respond to temperature changes even when no medium is discharged from the heat exchanger.

1. Weld on a pipe socket with female thread (socket-weld design) of approx. 40 mm in length at the place of installation (this also applies when a thermowell is used).
2. Remove the double nipple (14) or thermowell (if used) from the sensor (16) and seal it into the welded socket.
3. Adjust the highest possible set point on the set point dial (12) using the key (11).
4. Insert the sensor with the associated seal into the double nipple or thermowell. Secure it with the coupling nut (7). The entire length of the temperature sensor (16) or thermowell must be immersed in the process medium.

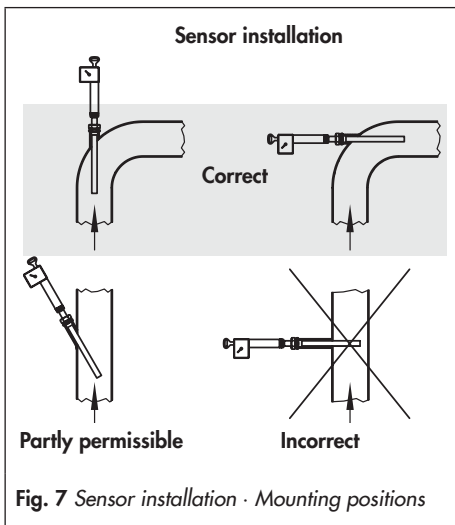

Fig. 7 Sensor installation · Mounting positions

Thermowell

When a thermowell is used, SAMSON recommends filling the free space between sensor and thermowell with oil or, when installed horizontally, with grease or any other heat transfer medium to avoid delays during heat transmission. This prevents heat transfer delays. Observe the thermal expansion of the filling medium. Allow some space for expansion and do not fill the entire free space or slightly loosen sensor nut for pressure compensation.

! NOTICE

Galvanic corrosion due to incorrectly selected materials of the mounting parts.
On installing the sensor or thermowell, only combine the same kind of materials (e.g. stainless steel with stainless steel or copper together with other copper materials).

4.2.2 Type 2234 (air sensor)

Type 2234 is designed for installation in air heaters, air ducts, drying cabinets etc. Install the sensor from the outside into the room and secure it with a special flange (accessories). The entire length of the sensor must be immersed in the air flow to be regulated.

Install the set point adjustment of Type 2234 in an easily accessible location.

Avoid locations with considerable ambient temperature fluctuations.

The perforated cover (accessories) is generally used for installation in manufacturing facilities, living spaces, baths etc.

Installation recommendations

Mount the sensor protected by a perforated cover to a suitable location on the middle of the wall.

Type 2234 with clamps (or perforated cover) is suitable for installation in drying chambers, dryers, air heaters, incubators etc.

In case of forced air circulation, install the sensor near the supply air inlet.

Mount the set point adjustment outside the room to be controlled in an easily accessible location. The set point adjustment must be exposed to a constant as possible temperature.

When regulating the temperature in greenhouses, make sure that the control thermostat and set point adjuster are not exposed to direct sunlight.

Installation

When the temperature regulating system is shut down during the summer, adjust a high set point to protect the control thermostat.

The following double nipples must be additionally used when the Type 2234 Control Thermostat is used to replace the Type 2233 Control Thermostat:

Table 2: *Double nipple*

Material number	Connection	Material
100166586	G to NPT	Stainless steel
100166585	G to G	
100174309	G to NPT	Brass
100174360	G to G	

4.2.3 Capillary tube

Carefully run the capillary tube (10) without bending or twisting it. Avoid locations with considerable ambient temperature fluctuations along the entire length of the tube.

i Note

Do not damage or shorten the capillary tube. Roll up any capillary tube that is not used. The smallest permissible bending radius is 50 mm.

4.3 Operating element

Attach the operating element (8) to the valve body using the coupling nut (7). If necessary, use the key (11) to adjust the highest possible set point, causing the pin of the operating element (9) to retract.

4.4 Dynamic behavior of control thermostats

The dynamics of the regulator are mainly determined by the response of the sensor with its characteristic time constant. The response times of SAMSON control thermostats operating according to different principles measured in water are listed below.

Table 3: *Time constants of SAMSON control thermostats*

Principle of operation	Type ... Control Thermostat	Time constant in s	
		Without Thermowell	With Thermowell
Liquid expansion	2231	70	120
	2232	65	110
	2234	15	– ¹⁾
	2213	70	120
Adsorption	2212	– ¹⁾	40

¹⁾ Not permissible

5 Operation

See Fig. 2 on page 7.

5.1 Start-up

The temperature regulator is first sealed when the operating element is fastened onto the bottom section.

Only open the shut-off valves in the plant after the control thermostat has been mounted on the valve.

WARNING

Risk of injury due to process medium escaping possibly under pressure.

→ Screw the operating element of the control thermostat tightly to the valve to seal the body connection. Afterwards, open the shut-off valves!

NOTICE

Process medium leakage due to missing seal at the sensor.

The use of a thermowell is mandatory in combination with a Type 2232 Control Thermostat with clamping gland.

Fill the plant slowly with the process medium.

5.2 Set point adjustment

Only use the key (11) to adjust the required temperature set point at the set point dial (12).

5. Slowly open the hand-operated shut-off valve downstream of the valve and then the shut-off valve upstream of the valve.
6. Check the adjusted temperature set point at the thermometer installed near the temperature sensor.
7. Slowly turn the key clockwise (↻) to increase the temperature and counterclockwise (↺) to reduce it.

Tip

Higher set point temperatures can be adjusted in increments as required. However, to lower the set point temperature, proceed in steps of 10 to 20 °C. When doing so, wait for the process medium to cool down before continuing. Watch the thermometer.

5.2.1 Correcting the set point dial

There are many ways to combine the temperature regulators with control thermostats that have varying proportional control action. As a result, the temperature adjusted on the dial often deviates from the actual temperature (measured by a reference thermometer).

The temperature can be corrected by turning the dial housing:

1. Undo the screw labeled "Korrektur" on the back of the dial housing.
2. Turn the entire dial housing until the dial shows the same temperature as the reference thermometer.
3. Retighten the screw marked "Korrektur".

Viewed from the front with the dial housing on top. A 360° turn corresponds to a set point change of approx. 1.5 °C.

- Turn clockwise ☺:
To increase the set point.
- Turn counterclockwise ☹:
To reduce the set point.

6 Mounting additional parts

See Fig. 8 on page 17.

6.1 Extension piece

An extension piece is installed between valve and control thermostat to protect the operating element of the control thermostat against high temperatures.

An extension piece is required: from 220 °C to max. 350 °C (max. 300 °C when EN-GJL-250 is used).

A control thermostat can be exchanged on site to install an extension piece, separating piece or double adapter.

Remember that process medium can escape while unscrewing the operating element. Therefore, take necessary precautions to prevent this.

⚠ WARNING

Risk of injury due to process medium escaping possibly under pressure.

→ *Depressurize the relevant section of the pipeline and, if necessary, drain it as well. When used at high temperatures, allow the plant section to cool down to ambient temperature.*

How to proceed:

1. Adjust the highest possible temperature set point, causing the pin of operating element to detach itself from the plug stem of the valve.

2. Unscrew the operating element.
3. Screw extension piece onto the valve body. Remount the operating element.
4. Adjust the set point as described in Chapter 5.2 on page 15.

6.2 Intermediate piece

Mounted between the operating element and valve. In stainless steel regulators, it separates the operating element made free of non-ferrous metals from the medium in the valve. In addition, it prevents the medium from escaping on removing the control thermostat.

Version I: The spindle (2) is fitted with O-rings which seals the operating element against the process medium.

Version II: A metal bellows is used as a sealing element.

For mounting, proceed as described in Chapter 6.1.

6.3 Double adapter

The double adapter allows a further control thermostat to be connected to achieve additional temperature regulation.

For mounting, proceed as described in Chapter 6.1.

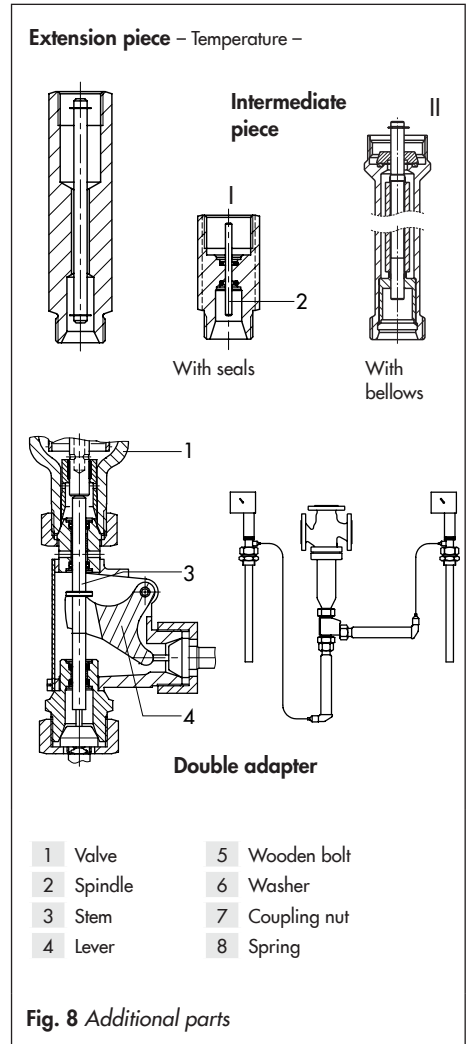

7 Maintenance – Replacing parts

See Fig. 2 on page 7.

The temperature regulators do not require much maintenance. Nevertheless, they are subject to natural wear, particularly at the seat and plug.

Depending on the operating conditions, check the valve and control thermostat at regular intervals to avoid possible malfunctions.

If the temperature exceeds the value adjusted at the control thermostat, possible causes include:

- The control thermostat is defective due to excessive temperatures.
- Valve seat and plug are contaminated with dirt.
- Seat and plug leak due to natural wear.

On exchanging the control thermostat, remember that process medium can escape while unscrewing the operating element. Therefore, take necessary precautions to prevent this.

WARNING

Risk of injury due to process medium escaping possibly under pressure.

→ Depressurize the relevant section of the pipeline and, if necessary, drain it as well. When used at high temperatures, allow the plant section to cool down to ambient temperature.

NOTICE

Process medium leakage due to missing seal at the sensor.

The use of a thermowell is mandatory in combination with a Type 2232 Control Thermostat with clamping gland.

How to proceed:

Exchanging the control thermostat and checking the seat and plug

1. If the control thermostat still works, adjust the highest possible temperature set point, causing the pin (9) of operating element to detach itself from the plug stem of the valve.
2. Unscrew the coupling nut (7) and remove the operating element (8). Process medium still in the valve may escape.
 - Mount new control thermostat and fasten it tightly to the bottom section (4) using the coupling nut (7).

Checking the seat and plug

3. Unscrew the valve flange together with the bottom section (4) from the valve body and pull them out downward.
4. Clean the seat (2) and plug (3) and, if necessary, renew them.

7.1 Troubleshooting

The listed examples of malfunctions are caused by mechanical faults in the valve or control thermostat as well as incorrect regulator sizing.

In the simplest case, the functioning can be restored following the recommended action. To repair the regulator, read the operating instructions for the corresponding regulator.

As in many cases, special tools are required, we advise you to contact SAMSON after-sales service to find out how to proceed to repair the regulator or replace a component.

Exceptional operating and installation conditions can lead to changed situations that may affect the control response and lead to malfunctions. In such cases, check the installation conditions, process medium, temperature and pressure conditions. A thorough analysis may often require the on-site assistance of SAMSON's After-sales Service.

Table 4 is not intended to be exhaustive as there are diverse reasons for malfunctions.

Table 4: *Troubleshooting*

Temperature regulators for heating applications	
Possible reasons	Recommended action
Temperature at the sensor exceeds the set point.	
Leak at seat and plug	Remove valve from the pipeline and clean seat and plug. Renew plug, if necessary. If this is not possible, return regulator to SAMSON for repair.
Valve too large for control task	Recalculate K_{VS} coefficient. Contact SAMSON.
Sensor installed in the wrong location.	The entire length of the temperature sensor must be immersed in the process medium and where idle times cannot occur. Change mounting position accordingly.
The temperature at the sensor has exceeded the permissible excess temperature (100 K). The stem stands out of the housing of the set point dial and does not move back into the housing after the temperature has dropped again.	The operating element has been damaged due to an excessively high temperature. Repair by SAMSON. In mixing valves: port A opens In diverting valves: port B is closed.
Temperature at the sensor does not reach the set point.	
Nominal size (DN) of the valve is too small for the control task.	Recalculate K_{VS} coefficient. Contact SAMSON.
A safety device (e.g. STL, STM etc.) has been triggered. Mixing valve: Port B closed Diverting valve: Port A closed	Check plant. Unlock safety device.
Insufficient heating energy available	Draw up an energy balance.
Strainer blocked	Drain and clean filter of the strainer.
Incorrectly installed valve	During installation, observe the correct direction of flow and arrangement of the ports A/B/AB (see Fig. 2 on page 7).
Control loop hunts.	
Nominal size (DN) of the valve is too large for the control task.	Recalculate K_{VS} coefficient. Contact SAMSON.
Time constant is too large for the control loop.	Fill the thermowell with thermal paste, remove thermowell or use sensor with smaller time constant.

Temperature regulators for cooling applications	
Possible reasons	Recommended action
Temperature at the sensor does not reach the set point.	
Leak at seat and plug	Remove valve from the pipeline and clean seat and plug. Renew plug, if necessary. If this is not possible, return regulator to SAMSON for repair.
Valve too large for control task	Recalculate K_{VS} coefficient. Contact SAMSON.
Sensor installed in the wrong location.	The entire length of the temperature sensor must be immersed in the process medium and where idle times or heat buildup cannot occur. Change mounting position accordingly.
A safety device (e.g. STL, STM etc.) has been triggered. Mixing valve: Port B closed Diverting valve: Port A closed	Check plant. Unlock safety device.
Temperature at the sensor exceeds the set point.	
Nominal size (DN) of the valve is too small for the control task.	Recalculate K_{VS} coefficient. Contact SAMSON.
Control thermostat defective	Mixing valve: port A closed · Diverting valve: port B is closed. Send the control thermostat back to SAMSON for repair.
Insufficient cooling energy available	Draw up an energy balance.
Strainer blocked	Drain and clean filter of the strainer.
Incorrectly installed valve	During installation, observe the correct direction of flow and arrangement of the ports A/B/AB (see Fig. 2 on page 7).
Control loop hunts.	
Nominal size (DN) of the valve is too large for the control task.	Recalculate K_{VS} coefficient. Contact SAMSON.
Time constant is too large for the control loop.	Fill the thermowell with thermal paste, remove thermowell or use sensor with smaller time constant.

8 Markings on the device

Several nameplates are affixed to the device. The nameplates shown were up to date at the time of publication of this document. The nameplates on the device may differ from the ones shown. The nameplates are used to identify the separate regulator components (see Chapter 8.1).

8.1 Nameplates

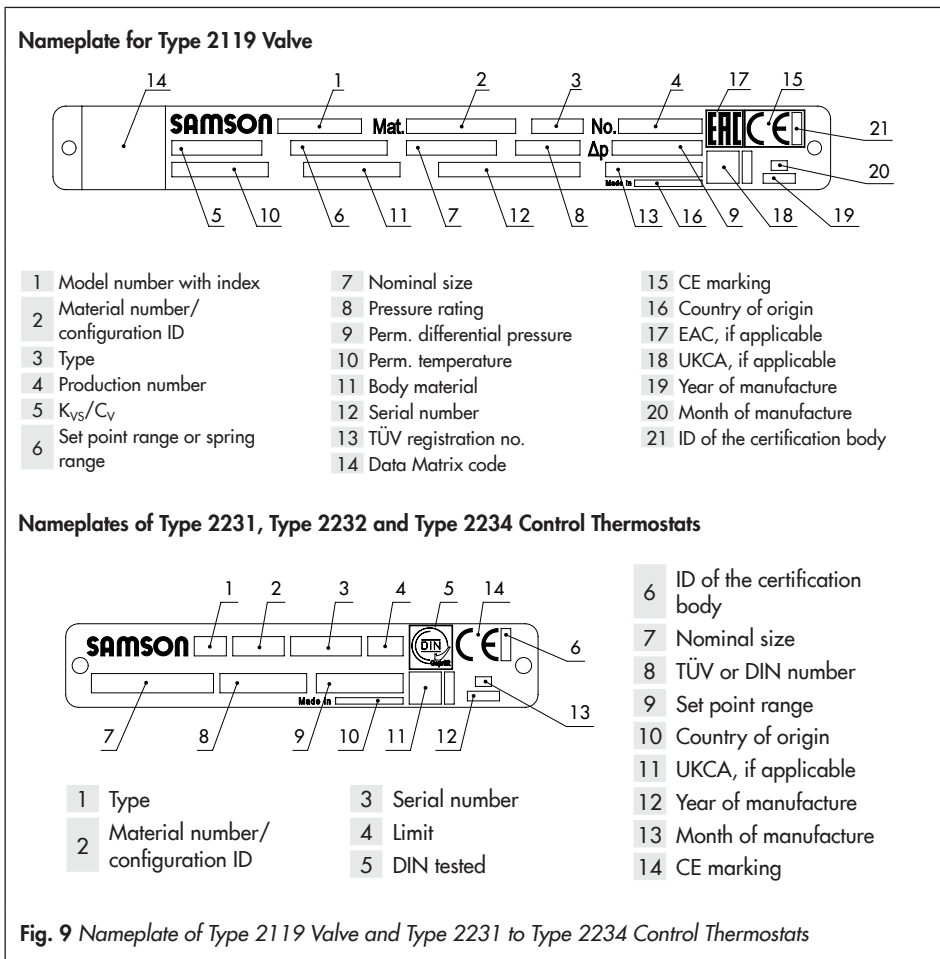

8.2 Location of the nameplates

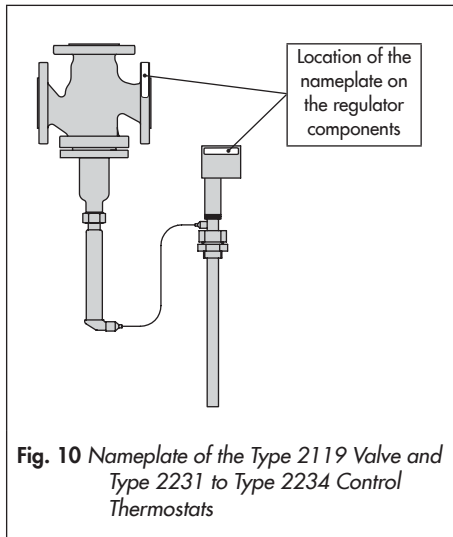

8.3 Material identification number

8.3.1 Type 2119 Valve

See the nameplate (11 for DIN/ANSI version, body material) for the material used. For more details on the nameplate, see Chapter 8.1.

8.3.2 Types 2231 to 2234 Control Thermostat

Specifying the material number, you can contact SAMSON to find out which material is used. It is specified on the nameplate in the 'MNo.' field (2). For more details on the nameplate, see Chapter 8.1.

9 Disposal



SAMSON is a producer registered at the following European institution
▶ <https://www.ewrn.org/national-registers/national-registers>.
WEEE reg. no.:
DE 62194439/FR 025665

- Observe local, national and international refuse regulations.
- Do not dispose of components, lubricants and hazardous substances together with your other household waste.

i Note

SAMSON can provide you with a recycling passport according to PAS 1049 on request. Simply e-mail us at aftersaleservice@samsongroup.com giving details of your company address.

Tip

On request, SAMSON can appoint a service provider to dismantle and recycle the product.

10 After-sales service

Contact SAMSON's After-sales Service for support concerning service or repair work or when malfunctions or defects arise.

E-mail address

You can reach our after-sales service at aftersaleservice@samsongroup.com.

Addresses of SAMSON AG and its subsidiaries

The addresses of SAMSON, its subsidiaries, representatives and service facilities worldwide can be found on our website (▶ www.samsongroup.com) or in all SAMSON product catalogs.

Required specifications

Please submit the following details:

- Model and nominal size of the valve, Type ... Control Thermostat
- Model number with index
- Upstream and downstream pressure
- Temperature and process medium
- Min. and max. flow rate
- Is a strainer installed?
- Installation drawing showing the exact location of the regulator and all the additionally installed components (shut-off valves, thermometer etc.).

11 Dimensions and weights

Table 5: Dimensions in mm and weights in kg

Type 9 Temperature Regulator															
Nom. size	DN		15	20	25	32	40	50	65	80	100	125	150		
Length L	mm	Type 2119 Valve	130	150	160	180	200	230	290	310	350	400	480		
H	mm		525			530		535		610		645		685	790
H1 ¹⁾	mm		235			240		245		320		355		395	500
H2 ¹⁾	mm		70	80	85	100	105	120	130	140	150	200	210		
Weight ²⁾ , approx.	kg		6	7	8.5	15	17	19	32	50	71	On request			
²⁾ Change in length with extension piece: +55 mm and with separating piece: +140 mm/180 mm ³⁾ For PN 16; PN 25/40: +15 %															

Control thermostat	Type	2231	2232	2234
Immersion depth T	mm	290	235	460
Weight, approx.	kg	3.2	4	3.7

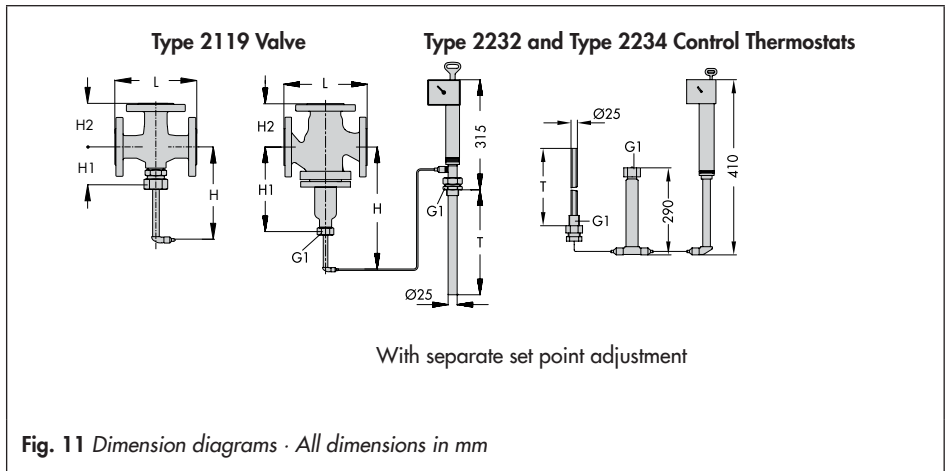

11.1 Accessories

Type 2234 · Clamps and perforated cover for wall mounting

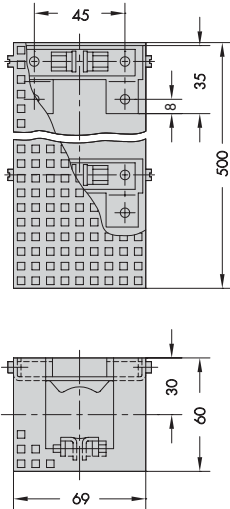

To mount the set point adjuster or sensor to a wall, suitable clamps (photo) are available.

The clamps for the sensor are integrated into the perforated cover.

Permissible mounting position of sensor: tip of sensor pointing down

Clamp with bracket

For set point adjuster (Ø40 mm) Order no.: 8395-0039

For sensor (Ø25 mm) ¹⁾ Order no.: 8395-0037

1 pair of clamps for set point adjuster (Types 2232, 2234) Order no.: 1400-5592



¹⁾ Max. tightening torque of locking screw for the clamp (sensor): 2.5 Nm

Extension piece/separating piece

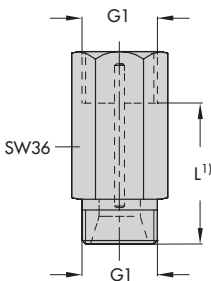

Extension piece

Standard version

L = approx. 140 mm, approx. 0.5 kg

With bellows seal (special version)

L = approx. 180 mm, approx. 0.6 kg

Separating piece with seals

L = approx. 55 mm, approx. 0.2 kg

¹⁾ Add the dimension L to H and H1 (see Table 5) when these accessories are used.

Fig. 12 Dimensions of accessories · Dimensions in mm

Type 2231/2232 · Thermowells

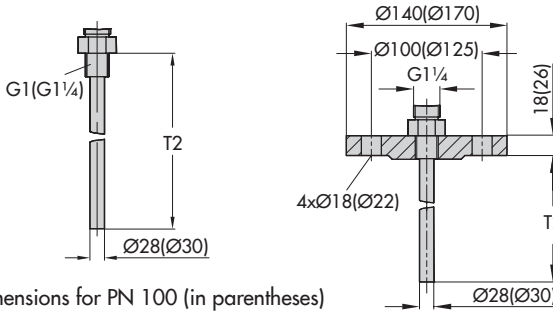

Dimensions for PN 100 (in parentheses)

With threaded connection G 1 for PN 40 and PN 100

With **flanges** DN 32 for PN 40 · DN 40 for PN 100

Control thermostat	Type 2231	Type 2232
Immersion depth T2	325 mm	250 mm

Type 2231/2232 · Thermowells for flammable gases (G 1/PN 100)

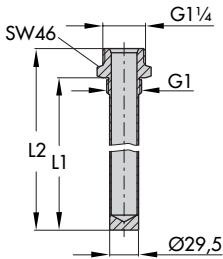

Control thermostat	Type 2231	Type 2232
Length L1	315 mm	255 mm
Length L2	340 mm	280 mm

Type 2234 · Flanges

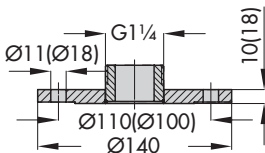

Flange PN 6, 140 Outside Ø · Flange PN 40/DN 32 (dimensions in parentheses)

Fig. 13 Dimensions of accessories · Dimensions in mm

EB 2133 EN



SAMSON AKTIENGESELLSCHAFT
Weismüllerstraße 3 · 60314 Frankfurt am Main, Germany
Phone: +49 69 4009-0 · Fax: +49 69 4009-1507
samson@samsongroup.com · www.samsongroup.com