

MOUNTING AND OPERATING INSTRUCTIONS



EB 6134 EN

Translation of original instructions



Type 6134-04 p/i Converter with one or two p/i converter units, rail-mounting unit



Type 6134-x3 p/i Converter, field unit

Type 6134 p/i Converter for two-wire connection

Edition May 2021

CE EAC Ex
certified

Note on these mounting and operating instructions

These mounting and operating instructions assist you in mounting and operating the device safely. The instructions are binding for handling SAMSON devices. The images shown in these instructions are for illustration purposes only. The actual product may vary.

- For the safe and proper use of these instructions, read them carefully and keep them for later reference.
- If you have any questions about these instructions, contact SAMSON's After-sales Service (aftersaleservice@samsongroup.com).



Documents relating to the device, such as the mounting and operating instructions, are available on our website at www.samsongroup.com > **Service & Support > Downloads > Documentation.**

Definition of signal words

DANGER

Hazardous situations which, if not avoided, will result in death or serious injury

WARNING

Hazardous situations which, if not avoided, could result in death or serious injury

NOTICE

Property damage message or malfunction

Note

Additional information

Tip

Recommended action

1	Safety instructions and measures	1-1
1.1	Notes on possible severe personal injury	1-4
1.2	Notes on possible personal injury	1-4
1.3	Notes on possible property damage	1-5
1.4	Special instructions concerning explosion protection	1-6
2	Marking on the device	2-1
2.1	Nameplate	2-1
2.2	Article code	2-2
3	Design and principle of operation	3-1
3.1	Technical data	3-2
3.1.1	Dimensions in mm	3-4
4	Shipment and on-site transport	4-1
4.1	Accepting the delivered goods	4-1
4.2	Removing the packaging from the device	4-1
4.3	Transporting the device	4-1
4.4	Storing the device	4-1
5	Installation	5-1
5.1	Installation conditions	5-1
5.2	Preparation for installation	5-1
5.3	Mounting the converter	5-2
5.4	Electrical connection	5-2
5.5	Pneumatic connection	5-4
5.6	Accessories	5-6
6	Operation	6-1
7	Malfunction	7-1
7.1	Troubleshooting	7-1
7.2	Emergency action	7-2
8	Servicing	8-1
8.1	Tuning zero and span	8-1
8.2	Periodic inspection and testing of the converter	8-2
9	Removal	9-1
10	Repairs	10-1
10.1	Servicing explosion-protected devices	10-1
10.2	Returning devices to SAMSON	10-1
11	Disposal	11-1

Contents

12	Certificates	12-1
13	Annex	13-1
13.1	Accessories	13-1
13.2	After-sales service	13-1

1 Safety instructions and measures

Intended use

The Type 6134 p/i Converter converts a pneumatic signal into a standardized electric signal. It is especially used as an intermediate element between pneumatic and electric control and measuring equipment.

The pneumatic input signal from 0.2 to 1 bar is converted into an electric DC signal from 4 to 20 mA.

The device is designed to operate under exactly defined conditions (e.g. input signal, pressure). Therefore, operators must ensure that the device is only used in operating conditions that meet the specifications used for sizing the device at the ordering stage. In case operators intend to use the device in other applications or conditions than specified, contact SAMSON.

SAMSON does not assume any liability for damage resulting from the failure to use the device for its intended purpose or for damage caused by external forces or any other external factors.

➔ Refer to the technical data and nameplate for limits and fields of application as well as possible uses.

Reasonably foreseeable misuse

The device is not suitable for the following applications:

- Use outside the limits defined by the technical data

Furthermore, the following activities do not comply with the intended use:

- Use of non-original spare parts
- Performing service and repair work not described

Qualifications of operating personnel

The device must be mounted, started up, serviced and repaired by fully trained and qualified personnel only; the accepted industry codes and practices must be observed. According to these mounting and operating instructions, trained personnel refers to individuals who are able to judge the work they are assigned to and recognize possible hazards due to their specialized training, their knowledge and experience as well as their knowledge of the applicable standards.

Explosion-protected versions of this device must be operated only by personnel who has undergone special training or instructions or who is authorized to work on explosion-protected devices in hazardous areas.

Safety instructions and measures

Personal protective equipment

No personal protective equipment is required for the direct handling of the device.

We recommend checking the hazards posed by the plant and the process medium being used (e.g. ► GESTIS (CLP) hazardous substances database).

- Protective clothing, gloves, eye protection and respiratory protection in applications with hot, cold and/or corrosive media
- Wear hearing protection when working near the valve
- Hard hat
- Safety harness when working at height
- Safety footwear, ESD (electrostatic discharge) footwear, if necessary
- Check with the plant operator for details on further protective equipment.

Revisions and other modifications

Revisions, conversions or other modifications of the product are not authorized by SAMSON. They are performed at the user's own risk and may lead to safety hazards, for example. Furthermore, the product may no longer meet the requirements for its intended use.

Warning against residual hazards

To avoid personal injury or property damage, operators and operating personnel must prevent hazards by taking appropriate precautions. Plant operators and operating personnel must observe all hazard statements, warning and caution notes in these mounting and operating instructions.

Responsibilities of the operator

Operators are responsible for proper use and compliance with the safety regulations. Operators are obliged to provide these mounting and operating instructions as well as the referenced documents to the operating personnel and to instruct them in proper operation. Furthermore, operators must ensure that operating personnel or third parties are not exposed to any danger.

Responsibilities of operating personnel

Operating personnel must read and understand these mounting and operating instructions as well as the referenced documents and observe the specified hazard statements, warnings and caution notes. Furthermore, operating personnel must be familiar with the applicable health, safety and accident prevention regulations and comply with them.

Referenced standards, directives and regulations

Devices with a CE marking fulfill the requirements of the Directives (see the 'Certificates' section):

- Type 6134-0: 2014/30/EU, 2011/65/EU
- Type 6134-1: 2014/30/EU, 2014/34/EU, 2011/65/EU
- Type 6134-2: 2014/30/EU, 2014/34/EU, 2011/65/EU

Devices with an EAC marking fulfill the requirements of the Regulations (see the 'Certificates' section):

- TR CU 004/2011
- TR CU 020/2011

Referenced documentation

The following documents apply in addition to these mounting and operating instructions:

- Mounting and operating instructions of the upstream pneumatic components
- Mounting and operating instructions of the downstream electric measuring and control equipment
- The mounting and operating instructions of the components on which the converter is mounted (valve, actuator, valve accessories etc.).

1.1 Notes on possible severe personal injury

DANGER

Risk of fatal injury due to the ignition of an explosive atmosphere.

Incorrect installation, operation or maintenance of the device in potentially explosive atmospheres may lead to ignition of the atmosphere and ultimately to death.

- ➔ The following regulations apply to installation in hazardous areas: EN 60079-14 (VDE 0165, Part 1).
- ➔ Installation, operation or maintenance of the device must only be performed by personnel who has undergone special training or instructions or who is authorized to work on explosion-protected devices in hazardous areas.

Loss of Ex d protection due to opening the enclosure cover or damage to the thread.

The protection against any explosions occurring inside the device is only effective with flameproof gaps on the enclosure.

- ➔ Keep the enclosure cover firmly closed during operation.
- ➔ Put the device out of operation when its cover thread or connecting thread is damaged. Replace it with a new device.

1.2 Notes on possible personal injury

WARNING

Risk of personal injury through incorrect operation, use or installation as a result of information on the device being illegible.

Over time, markings, labels and nameplates on the device may become covered with dirt or become illegible in some other way. As a result, hazards may go unnoticed and the necessary instructions not followed. There is a risk of personal injury.

- ➔ Keep all relevant markings and inscriptions on the device in a constantly legible state.
- ➔ Contact our after-sales service to renew damaged, missing or incorrect nameplates or labels.

⚠ WARNING

Risk of personal injury due to exhaust air being vented.

While in operation, the device vents exhaust air over the vent plug.

- Locate the vent plug on the opposite side to the work position of operating personnel.

1.3 Notes on possible property damage

ⓘ NOTICE

Risk of device damage due to failure to meet air quality requirements.

Insufficient air quality can damage components and seals inside the device.

- Only use supply air that is dry and free of oil and dust.
- Observe the air quality according to ISO 8573-1: 2001.
- Blow through all air pipes and hoses thoroughly before connecting them.

Risk of device damage due to the maximum supply pressure being exceeded.

The maximum supply pressure for the device is restricted. A supply pressure higher than the maximum permissible supply pressure may damage the device.

- Refer to the technical data for the maximum permissible supply pressure.
- Make sure that the air supply does not exceed the maximum permissible supply pressure.

1.4 Special instructions concerning explosion protection

Servicing explosion-protected devices

- Observe the following for servicing equipment in a section relevant for explosion protection:

It must not be put back into operation until a qualified inspector has assessed the equipment according to explosion protection requirements, has issued an inspection certificate or given the device a mark of conformity. Inspection by a qualified inspector is not required if the manufacturer performed a routine test on the device before putting it back into operation. Document the passing of the routine test by attaching a mark of conformity to the device.

Replace explosion-protected components only with original, routine-tested components by the manufacturer.

Devices that have already been used outside hazardous areas and are intended for future use inside hazardous areas must comply with the safety requirements placed on serviced devices. They must be subjected to testing according to the specifications in EN 60079-19.

EN 60079-19 applies to servicing explosion-protected devices.

2 Marking on the device

2.1 Nameplate

The nameplates shown were up to date at the time of publication of this document. The nameplate on the device may differ from the one shown.

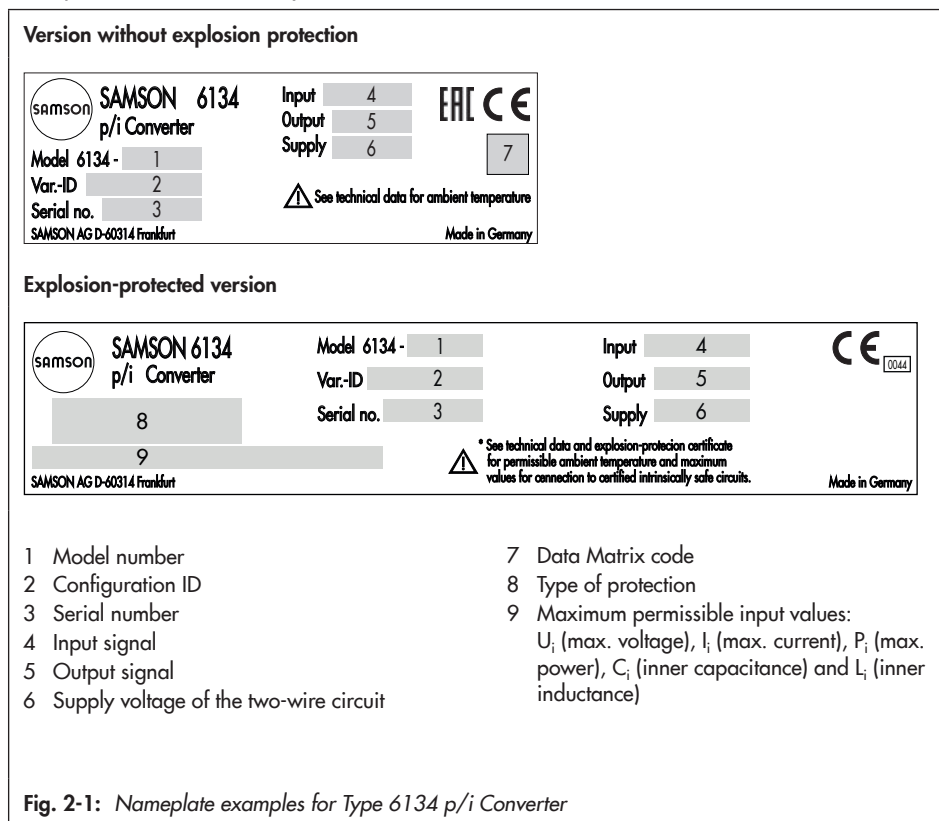

Location of the nameplate

- Rail-mounting unit: the nameplate is located at the front of the device.
- Field unit: the nameplate is affixed with grooved pins to the side of the p/i converter.

2.2 Article code

Type 6134-	x	x	x	x	x	x	x	x	x	x
Explosion protection										
Without	0									
ATEX: II 2G EEx ia IIC T6	1	3								
ATEX: II 2G EEx d IIC T6	2	3								
Version										
Field unit		3	0							
Rail-mounting unit										
With one p/i converter unit	0	4	1							
With two p/i converter units	0	4	2							
Input										
0.2 to 1 bar				1						
3 to 15 psi				2						
Electrical connection										
Rail-mounting unit, screw terminals	0	4			0					
Field unit, ½-14 NPT		3	0		1					
Field unit, M20x1.5		3	0		2					
Pneumatic connection										
Hose connection	0	4			0	0				
¼-18 NPT		3	0			1				
ISO-228/1 - G ¼		3	0			2				
Degree of protection										
IP 20	0	4			0	0	0			
IP 54		3	0				1			
IP 65		3	0				2			
Pressure gauge										
Without								0		
With		3	0					1		
Temperature range										
T _{min} ≥ -20 °C									0	
T _{min} ≥ -40 °C		3	0						1	
Output signal										
4 to 20 mA										0

3 Design and principle of operation

The Type 6134 p/i Converter converts a pneumatic signal into a standardized electric signal. It is especially used as an intermediate element between pneumatic and electric control and measuring equipment.

The pneumatic input signal from 0.2 to 1 bar is converted into an electric DC signal from 4 to 20 mA.

Principle of operation (see Fig. 3-2)

A capacitive ceramic pressure sensor (1) is used to convert the pressure p of the pneumatic input signal into an electric DC voltage signal. The DC voltage signal which is proportional to the pressure is amplified to a defined level in the measuring amplifier (3). The lower range value and span can be adjusted using potentiometers on the front panel.

el. The constant DC voltage source (2) is used to supply the DC voltage at a constant level. Control equipment can be connected to the output circuit.

Output circuit

In two-wire systems, the maximum permissible load impedance at the output is:

$$U_B = U_S - U_A \quad R_B = U_B / 20 \text{ mA}$$

- U_B Maximum permissible load impedance
- R_B Maximum permissible load
- U_S Supply voltage of the two-wire circuit
- U_A 12 V, input voltage requirement (minimum connected voltage required)

Example: $U_S = 20 \text{ V DC}$

Maximum permissible load impedance at the output: $U_B = 20 \text{ V} - 12 \text{ V} = 8 \text{ V}$

Load: $R_B = U_B / 20 \text{ mA} = 400 \Omega$

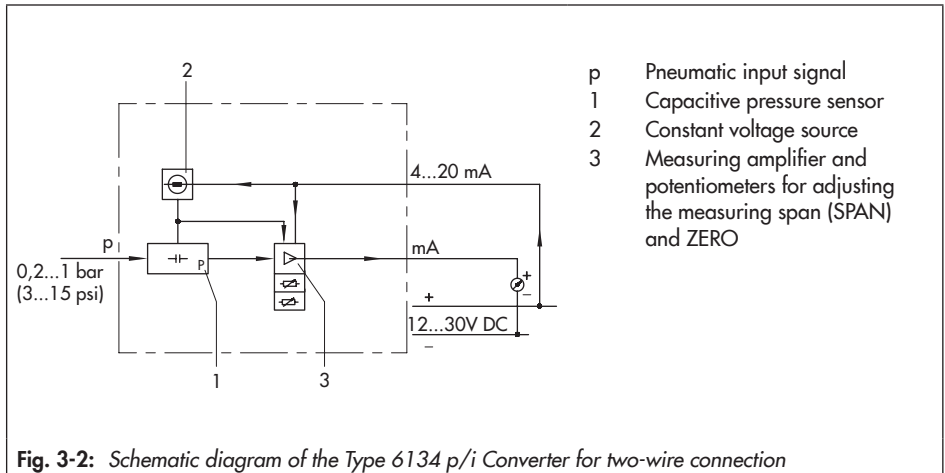

Fig. 3-2: Schematic diagram of the Type 6134 p/i Converter for two-wire connection

3.1 Technical data

Type	Type 6134-04	Types 6134-03, -13, -23
Version	Rail-mounting unit	Field unit
Explosion protection according to ATEX	–	II 2G EEx ia IIC T6 II 2G EEx d IIC T6
p/i converter unit/device	1 or 2	1
Input	0.2 to 1 bar (3 to 15 psi), overloadable up to 5 bar (72.5 psi)	
Output	4 to 20 mA ^{1), 2)}	
Perm. load at 0/4 to 20 mA	$R_b = \frac{U_S - 12 V}{20 \text{ mA}}$, $U_S = \text{supply voltage}$	
Supply voltage	Two-wire network Voltage range 12 to 30 V DC ^{1) 2)}	
Characteristic		
Characteristic	Output linear to input	
Hysteresis	Negligible	
Deviation from terminal-based linearity	Terminal-based conformity: $\leq 0.2 \% ^3)$	
Ripple of output signal	$\leq 0.5 \% ^3)$	
Effect of temperature	$\leq 0.15 \% / 10 \text{ K}$ for zero and span	
EMC noise emission	EN 61000-6-3	
EMC noise immunity	EN 61000-6-2	
Ambient conditions, degree of protection, weight		
Permissible ambient temperature	–20 to +70 °C	Without explosion protection: –20 to 70 °C –40 to 70 °C (only with IP 65) With explosion protection ²⁾ : –20 to 60 °C –40 to 60 °C (only with IP 65)
Perm. storage temperature	–40 to +80 °C	–40 to +80 °C
Perm. transportation temperature	–40 to +80 °C	–40 to +80 °C
Degree of protection acc. to EN 60529	IP 20	IP 54/IP 65

Type	Type 6134-04	Types 6134-03, -13, -23
Version	Rail-mounting unit	Field unit
Weights		
1 converter unit	0.225 kg	1.005 kg
2 converter units	0.285 kg	–
Installation and connections		
Mounting orientation	Any	Vent plug facing downward
Air connection	Hose connection for 4x1 mm, 6 mm outside diameter	2x tapped holes (use of left or right hole optional): ISO 228/1 - G ¼ or ¼-18 NPT
Electrical connection		
Female thread	–	M20x1.5 or ½-14 NPT
Terminals for wires	0.5 to 2.5 mm ²	0.5 to 2.5 mm ² (internal)
Fixed wires	0.2 to 4 mm ²	0.2 to 4 mm ²
Flexible wires	0.2 to 2.5 mm ²	0.2 to 2.5 mm ²
Mounting		
	35 mm top-hat rail, DIN EN 60715	Bracket for wall mounting (included in scope of delivery) or pipe mounting for 2" pipes (order no. 1400-5656)

- 1) Type 6134-13: intrinsically safe circuit
- 2) See 'Certificates' section for details (electric data, connection conditions, etc.)
- 3) All errors specified based on output span

3.1.1 Dimensions in mm

Rail-mounting unit

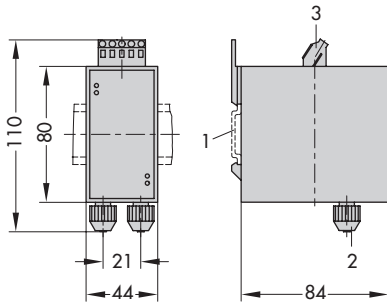

- 1 Top-hat rail
- 2 Pneumatic connection (input)
- 2* Pneumatic connection (input)
optional use of left or right
- 3 Electrical connection (output)
- 4 Pipe mounting (order no. 1400-5656)
- 5 Wall mounting material included in
scope of delivery (order no. 1400-8837)
- 6 Vent plug IP 54/IP 65
- 7 Pressure gauge (order no. 1400-8838)

Field unit

- Pipe mounting for 2" pipes (below)
- Wall mounting (right)

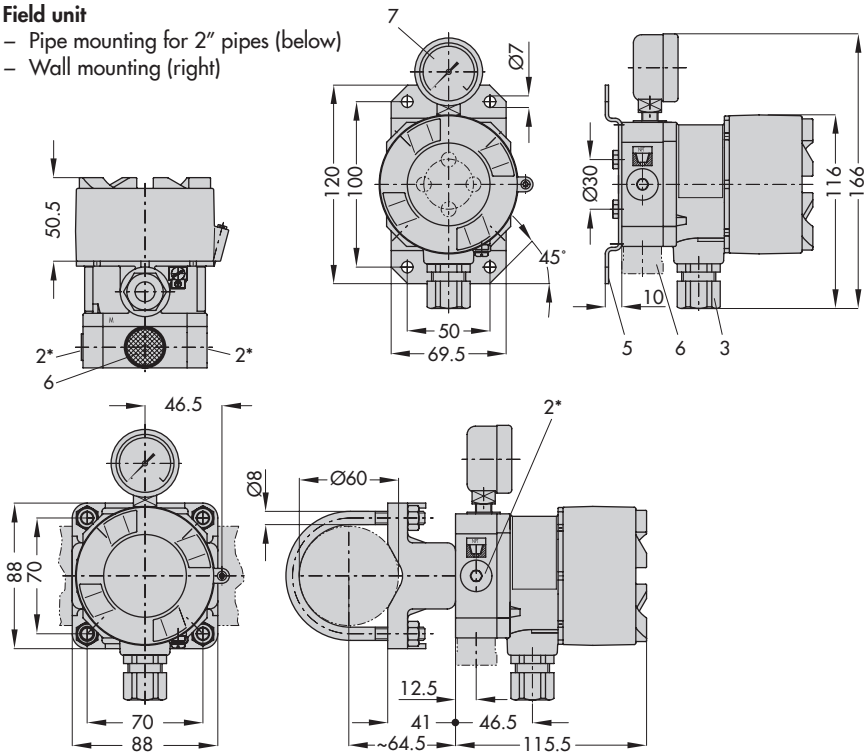

4 Shipment and on-site transport

The work described in this section is only to be performed by personnel appropriately qualified to carry out such tasks.

4.1 Accepting the delivered goods

After receiving the shipment, proceed as follows:

1. Check the scope of delivery. Check that the specifications on the nameplate of the device match the specifications in the delivery note. See the 'Markings on the device' section for nameplate details.
2. Check the shipment for transportation damage. Report any damage to SAMSON and the forwarding agent (refer to delivery note).

4.2 Removing the packaging from the device

Observe the following sequence:

- Do not remove the packaging until immediately before installation.
- Dispose and recycle the packaging in accordance with the local regulations.

4.3 Transporting the device

- Pack the device properly to comply with terms of transportation.

Transport instructions

- Protect the device against external influences (e.g. impact).
- Protect the device against moisture and dirt.
- Observe transport temperature (see the 'Design and principle of operation' section).

4.4 Storing the device

! NOTICE

Risk of device damage due to improper storage.

- Observe the storage instructions.
 - Avoid long storage times.
 - Contact SAMSON in case of different storage conditions.
-

! Note

We recommend regularly checking the prevailing storage conditions during long storage periods.

Shipment and on-site transport

Storage instructions

- Protect the device against external influences (e.g. impact, shocks, vibration).
- Do not damage the corrosion protection (coating).
- Protect the device against moisture and dirt. In damp spaces, prevent condensation. If necessary, use a drying agent or heating.
- Observe storage temperature (see the 'Design and principle of operation' section).
- Do not place any objects on the device.

5 Installation

The work described in this section is only to be performed by personnel appropriately qualified to carry out such tasks.

⚠ DANGER

Risk of fatal injury due to the ignition of an explosive atmosphere.

- Observe EN 60079-14 (VDE 0165, Part 1) for work on the converter in potentially explosive atmospheres.
- Work in potentially explosive atmospheres must only be performed by personnel who has undergone special training or instructions or who is authorized to work on explosion-protected devices in hazardous areas.

⚠ DANGER

Loss of Ex d protection due to opening the enclosure cover or damage to the thread.

- Keep the enclosure cover firmly closed during operation.
- Put the device out of operation when its cover thread or connecting thread is damaged. Replace it with a new device.

5.1 Installation conditions

Work position

The work position is the front view onto the operating controls on the device seen from the position of operating personnel.

Operators must ensure that, after installation of the device, the operating personnel can perform all necessary work safely and easily access the device from the work position.

Vent plug

- Locate the vent plug on the opposite side to the work position of operating personnel.

Mounting orientation

- **Rail-mounting unit**
The valve can be mounted in any desired position.
- **Field unit**
 - Install the converter horizontally with the pressure gauge (or screw plug) facing upward.
 - Install the converter with degree of protection IP 54 in such a way that the connection for the vent plug is always installed facing downward to the floor.

5.2 Preparation for installation

Before installation, make sure the following conditions are met:

- The converter is not damaged.
- The connections of the converter are clean.

Proceed as follows:

- Lay out the necessary material and tools to have them ready during installation work.

Installation

- Check any mounted pressure gauges to make sure they function properly.

5.3 Mounting the converter

a) Rail-mounting unit

The converter is mounted on a top-hat rail (DIN EN 60715).

- Snap the converter onto the top-hat rail.

b) Field unit

The converter is mounted to a wall or a pipe ($\varnothing 2''$) (see Fig. 5-1).

Wall mounting

The converter is delivered with a wall mounting bracket (see section 5.6 for order number).

- Fasten the mounting bracket to the back of the converter using two screws.
- Fasten the mounting bracket to the wall using four screws.

Pipe mounting ($\varnothing 2''$)

Required accessories: see section 5.6

- Unfasten the clamp from the mounting bracket.
- Fasten the mounting bracket to the back of the converter using two screws.
- Place the clamp around the pipe. Hold it in position and fasten it to the mounting bracket.

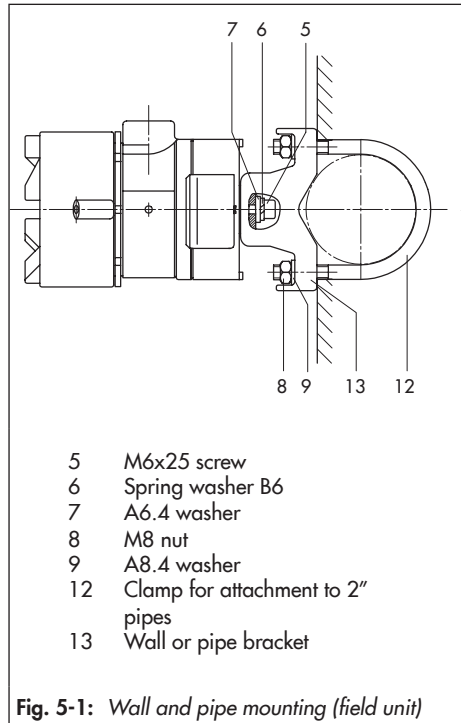

5.4 Electrical connection

For electrical installation, observe the relevant electrotechnical regulations and the accident prevention regulations that apply in the country of use. In Germany, these are the VDE regulations and the accident prevention regulations of the employers' liability insurance.

⚠ DANGER

Incorrect electrical connection will render the explosion protection unsafe.

- ➔ Adhere to the terminal assignment.
- ➔ Do not undo the enameled screws in or on the enclosure.
- ➔ Do not exceed the maximum permissible values specified in the EC type examination certificates when interconnecting intrinsically safe electrical equipment (U_i or U_{0r} , I_i or I_{0r} , P_i or P_{0r} , C_i or C_0 and L_i or L_0).

The ambient temperature ranges of the tables in the EC type examination certificate apply for the assignment between the permissible ambient temperature, temperature class, maximum short-circuit currents and maximum power P_i and P_0 .

The terminals of the converter are designed for wires with 0.5 to 2.5 mm².

a) Rail-mounting unit

- ➔ Connect the wires of the converter to the terminals (see Fig. 5-2).
Route the connecting lines for voltage supply and output signal separately.

b) Field unit

- ➔ Unscrew the enclosure cover.
- ➔ Connect the wires to the terminals 11 (+) and 12 (-) using suitable cable glands or connectors. See Fig. 5-2.

Route the connecting lines for voltage supply and output signal separately.

Connect Ex d versions with an approved metal cable entry (certificate of conformity) or a seal box pipe.

Fit approved versions (certificate of conformity) with permanently sealed cable entries.

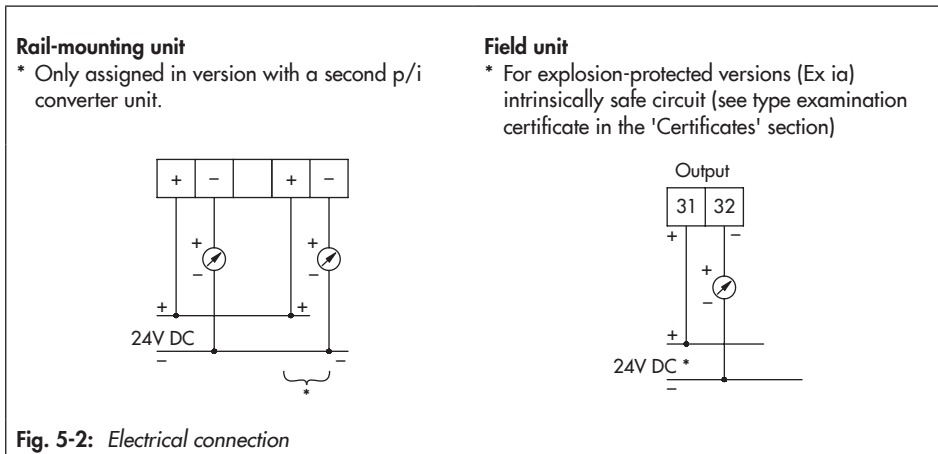

Installation

- Secure grounding conductor at the ground terminal located either inside or outside the enclosure.
- Place on the enclosure cover and fasten it.

5.5 Pneumatic connection

⚠ NOTICE

Risk of converter damage due to the maximum supply pressure being exceeded.

The maximum supply pressure for the converter is 5 bar above the input signal specified on the nameplate. A higher supply pressure may damage the converter.

- *Make sure that the input signal does not exceed the maximum supply pressure.*
-

Supply air quality requirements

- Only use supply air that is dry and free of oil and dust.
- Observe the air quality according to ISO 8573-1: 2001.
- Blow through all air pipes and hoses thoroughly before connecting them.

a) Rail-mounting unit

The connection is designed as a hose connection for 4x1 mm hose.

- Connect the air line from the upstream pneumatic device issuing the positioning value to the hose connection (see Fig. 5-3).

b) Field unit

The air connection is designed as a bore with G ¼ or ¼-18 NPT thread. Customary fittings for metal tubing or plastic hoses can be used.

- Connect the supply air line to the air connection (input). See Fig. 5-3.

Rail-mounting unit

* Only input 1 is assigned in the version with one p/i converter unit.

**Field unit**

Fig. 5-3: *Supply air line (input signal)*

5.6 Accessories

Mounting material for

- Bracket for wall mounting, stainless steel (1.4301)
- Wall and pipe mounting (2" pipes)

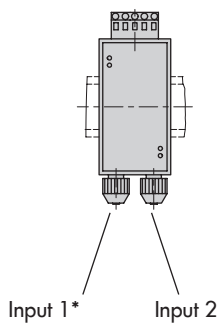
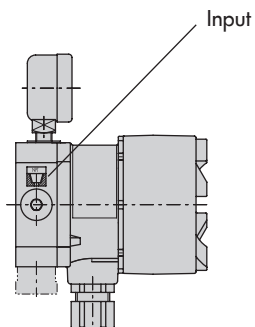
Order no.

1400-8837 (included
in scope of delivery)

1400-5656

Pressure gauge retrofit for field unit

- Pressure gauge including lock nut

1400-8838

6 Operation

The converter is ready for use after it has been mounted and the pneumatic and electric connections have been established (see the 'Installation' section).

Note

The converter is tested by SAMSON and the output signal is adjusted to the required range. In case of inconsistencies caused by the converter despite it being mounted correctly, the zero and span can be retuned (see the 'Servicing' section).

DANGER

Loss of Ex d protection due to opening the enclosure cover or damage to the thread.

- *Keep the enclosure cover firmly closed during operation.*
 - *Put the device out of operation when its cover thread or connecting thread is damaged. Replace it with a new device.*
-

7 Malfunction

⚠ DANGER

Risk of fatal injury due to the ignition of an explosive atmosphere.

- Observe EN 60079-14 (VDE 0165, Part 1) for work on the converter in potentially explosive atmospheres.
- Work in potentially explosive atmospheres must only be performed by personnel who has undergone special training or instructions or who is authorized to work on explosion-protected devices in hazardous areas.

⚠ DANGER

Loss of Ex d protection due to opening the enclosure cover or damage to the thread.

- Keep the enclosure cover firmly closed during operation.
- Put the device out of operation when its cover thread or connecting thread is damaged. Replace it with a new device.

⚠ DANGER

Incorrect electrical connection will render the explosion protection unsafe.

- Adhere to the terminal assignment.
- Do not undo the enameled screws in or on the enclosure.
- Do not exceed the maximum permissible values specified in the EC type examination certificates when interconnecting intrinsically safe electrical equipment (U_i or U_{0i} , I_i or I_{0i} , P_i or P_{0i} , C_i or C_0 and L_i or L_0).

ⓘ NOTICE

Risk of converter damage due to the maximum supply pressure being exceeded.

The maximum supply pressure for the converter is 5 bar. A higher supply pressure may damage the converter.

- Make sure that the input signal does not exceed the maximum supply pressure.

7.1 Troubleshooting

- See Table 7-1

i Note

Contact SAMSON's After-sales Service for malfunctions not listed in the table.

7.2 Emergency action

Plant operators are responsible for emergency action to be taken in the plant.

In the event of a converter malfunction:

1. Perform troubleshooting.
2. Rectify those malfunctions that can be remedied following the information given in these mounting and operating instructions. Contact our after-sales service in all other cases.

Putting the device back into operation after a malfunction

→ See the 'Start-up' section.

Table 7-1: *Troubleshooting*

Malfunction	Possible reasons	Corrective action to be taken
No output signal despite changing the input signal	Incorrect electrical connection	→ Check the electrical connection (see the 'Installation' section).
Output signal does not change proportionally into the input signal.	Incorrect pneumatic connection	→ Check the pneumatic connection (see the 'Installation' section).
p/i converter does not reach 100 % output e.g. 1 bar input: output only 70 % instead of 100 %	Zero and span shifted.	→ Tune zero and span (see the 'Installation' section).
	Incorrect electrical connection	→ Check electrical connection (see the 'Installation' section).
	Incorrect pneumatic connection	→ Check the pneumatic connection (see the 'Installation' section).

8 Servicing

The work described in this section is only to be performed by personnel appropriately qualified to carry out such tasks.

⚠ DANGER

Risk of fatal injury due to the ignition of an explosive atmosphere.

- Observe EN 60079-14 (VDE 0165, Part 1) for work on the converter in potentially explosive atmospheres.
- Work in potentially explosive atmospheres must only be performed by personnel who has undergone special training or instructions or who is authorized to work on explosion-protected devices in hazardous areas.

⚠ DANGER

Loss of Ex d protection due to opening the enclosure cover or damage to the thread.

- Keep the enclosure cover firmly closed during operation.
- Put the device out of operation when its cover thread or connecting thread is damaged. Replace it with a new device.

i Note

The device was checked by SAMSON before it left the factory.

- The product warranty becomes void if service or repair work not described in these instructions is performed without prior agreement by SAMSON's After-sales Service.

- Only use original spare parts by SAMSON, which comply with the original specifications.

8.1 Tuning zero and span

The **ZERO** and **SPAN** potentiometers are located directly on the front panel of the rail-mounting unit. To access these potentiometers on the field unit, unscrew the enclosure cover (see Fig. 8-1).

- Put any components upstream of the converter (e.g. air line for the input signal) out of operation.
- Remove any lines to upstream components and any wires to downstream control equipment (electric output signal line).
- Connect the pneumatic input to a pressure instrument and the electric output to a measuring instrument with sufficient accuracy.
- Unscrew the enclosure cover of the converter.
- Tune zero:
 - Set the input signal to 0.2 bar.

The output signal of the measuring instrument must now indicate 4 mA.
 - Correct deviations at the **ZERO** potentiometer.
- Tune span:
 - Raise the input signal from 0.2 bar to 1 bar.

The output signal of the measuring instrument must now indicate 20 mA.

Servicing

- Correct deviations at the **SPAN** potentiometer.
- As the adjustment of zero and span influence each other, recheck both zero and span and correct them, if necessary.

After tuning is completed:

- Place on the enclosure cover and fasten it.
- Disconnect the pressure instrument from the pneumatic input and the measuring instrument from the electric output.
- Connect the converter to the upstream components (pneumatic line for input signal) and to the downstream control equipment (electric line for output signal).

8.2 Periodic inspection and testing of the converter

We recommend inspection and testing according to Table 8-1 at the minimum.

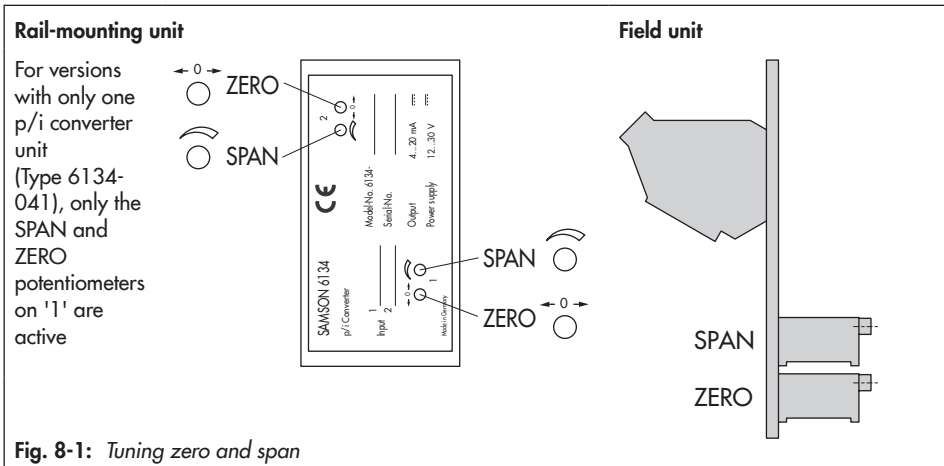

Table 8-1: *Recommended inspection and testing*

Inspection and testing	Action to be taken in the event of a negative result
Check the markings, labels and nameplates on the converter for their readability and completeness.	Contact SAMSON when nameplates or labels are damaged, missing or incorrect to renew them.
	Clean any inscriptions that are covered with dirt and are illegible.
Check the converter to ensure it is mounted firmly.	Tighten the any loose mounting screws.
Check air lines.	Tighten any loose connections.
	Renew damaged lines.
Check the electric wiring.	Make sure that the stranded wires are pushed into the terminals and tighten any loose screws on the the terminals.
	Renew damaged lines.

9 Removal

The work described in this section is only to be performed by personnel appropriately qualified to carry out such tasks.

DANGER

Risk of fatal injury due to the ignition of an explosive atmosphere.

- *Observe EN 60079-14 (VDE 0165, Part 1) for work on the converter in potentially explosive atmospheres.*
 - *Work in potentially explosive atmospheres must only be performed by personnel who has undergone special training or instructions or who is authorized to work on explosion-protected devices in hazardous areas.*
-

Removing the converter

- Make sure that the converter has been put out of operation properly (see the 'Decommissioning' section).
- Remove air lines.
- Disconnect the electrical wires.
- **Rail-mounting unit:**
Remove the converter from the top-hat rail.

Field unit:

Unscrew the four screws for wall mounting on the bracket.

10 Repairs

A defective device must be repaired or replaced.

! NOTICE

Risk of device damage due to incorrect service or repair work.

- Do not perform any repair work on your own.
- Contact SAMSON's After-sales Service for repair work.

10.1 Servicing explosion-protected devices

- Observe the following for servicing equipment in a section relevant for explosion protection:

It must not be put back into operation until a qualified inspector has assessed the equipment according to explosion protection requirements, has issued an inspection certificate or given the device a mark of conformity. Inspection by a qualified inspector is not required if the manufacturer performed a routine test on the device before putting it back into operation. Document the passing of the routine test by attaching a mark of conformity to the device.

Replace explosion-protected components only with original, routine-tested components by the manufacturer.

Devices that have already been used outside hazardous areas and are intended for future use inside hazardous areas must comply with the safety requirements placed on serviced devices. They must be subjected to testing according to the specifications in EN 60079-19.

EN 60079-19 applies to servicing explosion-protected devices.

10.2 Returning devices to SAMSON

Defective devices can be returned to SAMSON for repair.

Proceed as follows to return devices to SAMSON:

1. Put the device out of operation (see the 'Decommissioning' section).
2. Remove the device (see the 'Removal' section).
3. Proceed as described on the Returning goods page of our website
 ► www.samsongroup.com > Service & Support > After-sales Service > Returning goods

11 Disposal



SAMSON is a producer registered at the following European institution ► <https://www.ewrn.org/national-registers/national-registers>.
WEEE reg. no.:
DE 62194439/FR 025665

- ➔ Observe local, national and international refuse regulations.
- ➔ Do not dispose of components, lubricants and hazardous substances together with your other household waste.

i Information

We can provide you with a recycling passport according to PAS 1049 on request. Simply e-mail us at offersaleservice@samsongroup.com giving details of your company address.

💡 Tip

On request, we can appoint a service provider to dismantle and recycle the product as part of a distributor take-back scheme.

12 Certificates

The following certificates are included on the next pages:

- Type 6134-0: EU declaration of conformity
- Type 6134-1: EU declaration of conformity
- Type 6134-2: EU declaration of conformity
- TR CU certificate
- Type 6134-1: EC type examination certificate (ATEX)
- Type 6134-2: EC type examination certificate (ATEX)

The certificates shown were up to date at the time of publishing. The latest certificates can be found on our website:

▶ www.samsongroup.com > Products & Applications > Product selector > Signal converters > 6134



SAMSON

EU Konformitätserklärung / EU Declaration of Conformity / Déclaration UE de conformité

Die alleinige Verantwortung für die Ausstellung dieser Konformitätserklärung trägt der Hersteller/
This declaration of conformity is issued under the sole responsibility of the manufacturer/
La présente déclaration de conformité est établie sous la seule responsabilité du fabricant.
Für das folgende Produkt / For the following product / Nous certifions que le produit

p/i-Umformer / p/i-Converter / Convertisseur p/i Typ/Type/Type 6134

wird die Konformität mit den einschlägigen Harmonisierungsrechtsvorschriften der Union bestätigt /
the conformity with the relevant Union harmonisation legislation is declared with /
est conforme à la législation d'harmonisation de l'Union applicable selon les normes:

EMC 2014/30/EU	EN 61000-6-2:2005, EN 61000-6-3:2007 +A1:2011, EN 61326-1:2013
RoHS 2011/65/EU	EN 50581:2012

Hersteller / Manufacturer / Fabricant:

SAMSON AKTIENGESELLSCHAFT
Weismüllerstraße 3
D-60314 Frankfurt am Main
Deutschland/Germany/Allemagne

Frankfurt / Francfort, 2017-07-29

Im Namen des Herstellers/ On behalf of the Manufacturer/ Au nom du fabricant.

Hanno Zager
Leiter Qualitätssicherung/Head of Quality Management/
Responsable de l'assurance de la qualité

Dirk Hoffmann
Zentralabteilungsleiter/Head of Department/Chef du département
Entwicklungsorganisation/Development Organization



SAMSON

EU Konformitätserklärung / EU Declaration of Conformity / Déclaration UE de conformité

Die alleinige Verantwortung für die Ausstellung dieser Konformitätserklärung trägt der Hersteller/
This declaration of conformity is issued under the sole responsibility of the manufacturer/
La présente déclaration de conformité est établie sous la seule responsabilité du fabricant.
Für das folgende Produkt / For the following product / Nous certifions que le produit

p/i-Umformer / p/i-Converter / Convertisseur p/i Typ/Type/Type 6134-1...

entsprechend der EU-Baumusterprüfbescheinigung PTB 04 ATEX 2023 ausgestellt von der/
according to the EU Type Examination PTB 04 ATEX 2023 issued by/
établi selon le certificat CE d'essais sur échantillons PTB 04 ATEX 2023 émis par:

Physikalisch Technische Bundesanstalt
Bundesallee 100
D-38116 Braunschweig
Benannte Stelle/Notified Body/Organisme notifié 0102

wird die Konformität mit den einschlägigen Harmonisierungsrechtsvorschriften der Union bestätigt /
the conformity with the relevant Union harmonisation legislation is declared with/
est conforme à la législation d'harmonisation de l'Union applicable selon les normes:

EMC 2014/30/EU

EN 61000-6-2:2005, EN 61000-6-3:2007
+A1:2011, EN 61326-1:2013Explosion Protection 94/9/EC (bis/to 2016-04-19)
Explosion Protection 2014/34/EU (ab/from 2016-04-20)

EN 60079-0:2009, EN 60079-11:2012

RoHS 2011/65/EU

EN 50581:2012

Hersteller / Manufacturer / Fabricant:

SAMSON AKTIENGESELLSCHAFT
Weismüllerstraße 3
D-60314 Frankfurt am Main
Deutschland/Germany/Allemagne

Frankfurt / Francfort, 2017-07-29

Im Namen des Herstellers/ On behalf of the Manufacturer/ Au nom du fabricant.

Hanno Zager
Leiter Qualitätssicherung/Head of Quality Management/
Responsable de l'assurance de la qualité

Dirk Hoffmann
Zentralabteilungsleiter/Head of Department/Chef du département
Entwicklungsorganisation/Development Organization



EU Konformitätserklärung / EU Declaration of Conformity / Déclaration UE de conformité

Die alleinige Verantwortung für die Ausstellung dieser Konformitätserklärung trägt der Hersteller/
This declaration of conformity is issued under the sole responsibility of the manufacturer/
La présente déclaration de conformité est établie sous la seule responsabilité du fabricant.
Für das folgende Produkt / For the following product / Nous certifions que le produit

p/i-Umformer / p/i-Converter / Convertisseur p/i
Typ/Type/Type 6134-2...

entsprechend der EU-Baumusterprüfbescheinigung PTB 03 ATEX 1214 ausgestellt von der/
according to the EU Type Examination PTB 03 ATEX 1214 issued by/
établi selon le certificat CE d'essais sur échantillons PTB 03 ATEX 1214 émis par:

Physikalisch Technische Bundesanstalt
Bundesallee 100
D-38116 Braunschweig
Benannte Stelle/Notified Body/Organisme notifié 0102

wird die Konformität mit den einschlägigen Harmonisierungsrechtsvorschriften der Union bestätigt/
the conformity with the relevant Union harmonisation legislation is declared with/
est conforme à la législation d'harmonisation de l'Union applicable selon les normes:

EMC 2014/30/EU	EN 61000-6-2:2005, EN 61000-6-3:2007 +A1:2011, EN 61326-1:2013
Explosion Protection 94/9/EC (bis/to 2016-04-19) Explosion Protection 2014/34/EU (ab/from 2016-04-20)	EN 60079-0:2009, EN 60079-1:2007
RoHS 2011/65/EU	EN 50581:2012

Hersteller / Manufacturer / Fabricant:

SAMSON AKTIENGESELLSCHAFT
Weismüllerstraße 3
D-60314 Frankfurt am Main
Deutschland/Germany/Allemagne

Frankfurt / Francfort, 2017-07-29

Im Namen des Herstellers/ On behalf of the Manufacturer/ Au nom du fabricant.

H. Zager

Hanno Zager
Leiter Qualitätssicherung/Head of Quality Management/
Responsable de l'assurance de la qualité

D. Hoffmann

Dirk Hoffmann
Zentralabteilungsleiter/Head of Department/Chef de département
Entwicklungsorganisation/Development Organization



СЕРТИФИКАТ СООТВЕТСТВИЯ

№ ЕАЭС RU C-DE.ЭА11.В.00043/19

Серия **RU** № **0197352**

ОРГАН ПО СЕРТИФИКАЦИИ Общества с ограниченной ответственностью «ТМС РУС». Место нахождения (адрес юридического лица): Российская Федерация, 127083, город Москва, улица Верхняя Масловка, дом 20, строение 2; адрес места осуществления деятельности: Российская Федерация, 127083, город Москва, улица Верхняя Масловка, дом 20, строение 2, помещения № 18, 28. Аттестат аккредитации № РОСС RU.0001.11ЭА11 от 02.07.2015. Номер телефона: +7 (495) 221-18-04; адрес электронной почты: info@tms-cs.ru.

ЗАЯВИТЕЛЬ Общество с ограниченной ответственностью «Самсон Контролс». Место нахождения (адрес юридического лица) и адрес места осуществления деятельности: Российская Федерация, 109544, город Москва, бульвар Энтузиастов, дом 2, этаж 5, комната 11. ОГРН 1037700041026. Номер телефона: +7 (495) 777-45-45; адрес электронной почты: samson@samson.ru.

ИЗГОТОВИТЕЛЬ «SAMSON AG Mess- und Regeltechnik» Место нахождения (адрес юридического лица) и адрес места осуществления деятельности по изготовлению продукции: Weismüllerstrasse 3, D-60314 Frankfurt am Main, Германия.

ПРОДУКЦИЯ Преобразователи электроннеуматические типов 6109, 6111, 6112, 6116, 6126, 6132, 6134, 6151. Изготовление в соответствии со стандартами, указанными в приложении к сертификату соответствия на бланке № 0676626.
Серийный выпуск

КОД ТН ВЭД ЕАЭС 9032 81 000 0

СООТВЕТСТВУЕТ ТРЕБОВАНИЯМ Технических регламентов Таможенного союза: «О безопасности низковольтного оборудования» (ТР ТС 004/2011); «Электромагнитная совместимость технических средств» (ТР ТС 020/2011)

СЕРТИФИКАТ СООТВЕТСТВИЯ ВЫДАН НА ОСНОВАНИИ протокола сертификационных испытаний № Г506-5421 от 18.09.2019, выданного Испытательной лабораторией Ассоциации экспертов по сертификации и испытаниям продукции «Сертификационный центр НАСТХОЛ», аттестат аккредитации РОСС RU.0001.21Г506; протокола сертификационных испытаний № 190919-007-02/ИП от 22.10.2019, выданного испытательной лабораторией ООО «Инновационные решения», аттестат аккредитации РОСС RU.0001.21АВ90; акта о результатах анализа состояния производства № 00062-А от 04.07.2019 органа по сертификации Общества с ограниченной ответственностью «ТМС РУС»; руководства по эксплуатации 4218-ЭПП-2019.РЭ.
Схема сертификации – 1с

ДОПОЛНИТЕЛЬНАЯ ИНФОРМАЦИЯ Стандарты, в результате изменения которых на добросовестной основе обеспечивается соблюдение требований технического регламента: ГОСТ 12.2.007-0-75 «Система стандартов безопасности труда. Издания электротехнические. Общие требования безопасности»; ГОСТ 30604.6.2-2013 раздел 8 «Совместимость технических средств электромагнитная. Устойчивость к электромагнитным помехам технических средств, применяемых в промышленных зонах»; ГОСТ 30804.6.4-2013 раздел 7 «Совместимость технических средств электромагнитная. Электромагнитные помехи от технических средств, применяемых в промышленных зонах». Назначенный срок службы – 12 лет. Назначенный срок хранения – 2 года. Условия хранения указаны в руководстве по эксплуатации 4218-ЭПП-2019.РЭ.

СРОК ДЕЙСТВИЯ С 31.10.2019 ПО 30.10.2024

ВКЛЮЧИТЕЛЬНО

Руководитель (уполномоченное
лицо) органа по сертификации

(подпись)

Эксперт (эксперт-аудитор)
(эксперты (эксперты-аудиторы))

(подпись)

Халфин Салават Маулитбаевич
(и.о.)Ходоров Владимир Игоревич
(и.о.)

ПРИЛОЖЕНИЕ

К СЕРТИФИКАТУ СООТВЕТСТВИЯ № ЕАЭС RU C-DE.ЭА11.В.00043/19

Серия **RU** № **0676626** Лист 1 из 1

Стандарты, в соответствии с которыми изготавливается продукция

Обозначение стандарта	Наименование стандарта
IEC 60730-1:2013	Automatic electrical controls for household and similar use. Part 1. General requirements. Corrigendum 1
EN 50178-1999	Electronic equipment for use in power installations
IEC 61000-6-2:2016	Electromagnetic compatibility (EMC). Part 6-2: Generic standards. Immunity for industrial environments
EN 61000-6-3:2007	Electromagnetic compatibility (EMC). Part 6-3: Generic standards. Emission standard for residential, commercial and light-industrial environments
IEC 61010-1:2010	Safety requirements for electrical equipment for measurement, control, and laboratory use. Part 1: General requirements
EN 61326-1:2013	Electrical equipment for measurement, control and laboratory use. EMC requirements. Part 1: General requirements

Руководитель (уполномоченное
лицо) органа по сертификации

Халфин Салават Маулитбаевич
(подпись)

Халфин Салават Маулитбаевич
(Ф.И.О.)

Эксперт (эксперт-аудитор)
(эксперты (эксперты-аудиторы))

М.П.
(подпись)

Ходоров Владимир Игоревич
(Ф.И.О.)



(1) **EC TYPE EXAMINATION CERTIFICATE**

- (2) Equipment and Protective Systems Intended for Use in Potentially Explosive Atmospheres – **Directive 94/9/EC**
- (3) EC Type Examination Certificate Number

PTB 04 ATEX 2023

- (4) Equipment: Model 6134-.. p/i Converter
- (5) Manufacturer: SAMSON AG Mess- und Regeltechnik
- (6) Address: Weismüllerstr. 3, 60314 Frankfurt am Main, Germany
- (7) The equipment and any acceptable variation thereof are specified in the schedule to this certificate.
- (8) The Physikalisch-Technische Bundesanstalt, notified body number 0102 according to Article 9 of the Council Directive 94/9/EC of 23 March 1994, certifies that this equipment has been found to comply with the essential health and safety requirements relating to the design and construction of equipment and protective systems intended for use in potentially explosive atmospheres specified in Annex II to the Directive.

The examination and test results are recorded in confidential report.
PTB Ex 04-23466

- (9) The essential health and safety requirements are satisfied by compliance with

EN 50014:1997 + A1 + A2

EN 50020:2002

- (10) If the sign "X" is placed after the certificate number, it indicates that the equipment is subject to special conditions for safe use as specified in the schedule to this certificate.
- (11) According to the Directive 94/9/EC, this EC Type Examination Certificate relates only to the design and construction of the specified equipment. If applicable, further requirements of this Directive apply to the Manufacture and apply to the Manufacture and supply of this equipment.

(12) The marking of the equipment shall include the following:



Zertifizierungsstelle Explosionsschutz
By order

Braunschweig, 19 March 2004

(Signature) (Seal)
Dr.-Ing. U. Johannmeyer
Regierungsdirektor

(13) **S c h e d u l e**

(14) **EC Type Examination Certificate No. PTB 04 ATEX 2023**

(15) **Description of Equipment**

The Model 6134-1 p/i Converter serves for converting a standard pressure signal into a pressure-proportional current signal of 4 to 20 mA i the signal circuit.

The Model 6134-1 p/i Converter is a passive two-terminal network which may be connected to any certified intrinsically safe circuit, provided the permissible values of U_i , I_i and P_i are not exceeded.

The media used are on-combustible gases and vapours.

The equipment is intended for use inside and outside of hazardous locations.

The correlation between temperature classification and permissible ambient temperature ranges is shown in the table below:

Temperature class	Permissible ambient temperature range
T6	-40 °C ... 60 °C
T5	-40 °C ... 70 °C
T4	-40 °C ... 80 °C

Electrical data

Signal circuit

Type of protection; Intrinsic safety
EEx ia IIC only for connection to a
certified intrinsically safe circuit

Maximum values:

U_i = 28 V
 I_i = 115 mA
 P_i = 1 W

 L_i = negligible
 C_i = 5.3 nF

(16) Test report **PTB Ex 04-23466**

(17) Special conditions for safe use

None

(18) **Special health and safety requirements**

Are satisfied by compliance with the standards specified above.

Zertifizierungsstelle Explosionsschutz
By order

Braunschweig, 19 March 2004

(Signature) (seal)
Dr.-Ing. Johannsmeyer
Regierungsdirektor

TRANSLATION

(1) **EX TYPE EXAMINATION CERTIFICATE**

- (2) Equipment and Protective Systems Intended for Use in Potentially Explosive Atmospheres – **Directive 94/9/EC**
- (3) EC Type Examination Certificate Number

PTB 03 ATEX 1214

- (4) Equipment: Model 6134-2... P/I-Converter
- (5) Manufacturer: SAMSON AG Mess- und Regeltechnik
- (6) Address: Weismüllerstr. 3, 60314 Frankfurt am Main, Germany
- (7) The equipment and any acceptable variation thereof are specified in the schedule to this certificate.
- (8) The Physikalisch-Technische Bundesanstalt, notified body number 0102 according to Article 9 of the Council Directive 94/9/EC of 23 March 1994, certifies that this equipment has been found to comply with the essential health and safety requirements relating to the design and construction of equipment and protective systems intended for use in potentially explosive atmospheres specified in Annex II to the Directive.

The examination and test results are recorded in confidential report

PTB Ex 03-13388

- (9) The essential health and safety requirements are satisfied by compliance with
EN 50014:1997 + A1 + A2 **EN 50018:2000 + A1**
- (10) If the sign "X" is placed after the certificate number, it indicates that the equipment is subject to special conditions for safe use as specified in the schedule to this certificate.
- (11) This EC Type Examination Certificate relates only to the design and examination of the specified equipment in compliance with Directive 94/9/EC. Further requirements of this Directive apply to the manufacture and supply of this equipment. These requirements are not covered by this Certificate.

(12) The marking of the equipment shall include the following:

 **II 2 G EEx d IIC T6, T5 or T4**

Zertifizierungsstelle Explosionsschutz
By order

Braunschweig, 06. November 2003

(Signature)

(Seal)

Dr.-Ing. H. Wehinger
Direktor und Professor

(13) **S c h e d u l e**

(14) **EC Type Examination Certificate No. PTB 04 ATEX 2023**

(15) **Description of Equipment**

The Model 6134-1 p/i Converter serves for converting a standard pressure signal into a pressure-proportional current signal of 4 to 20 mA i the signal circuit.

The Model 6134-1 p/i Converter is a passive two-terminal network which may be connected to any certified intrinsically safe circuit, provided the permissible values of U_i , I_i and P_i are not exceeded.

The media used are on-combustible gases and vapours.

The equipment is intended for use inside and outside of hazardous locations.

The correlation between temperature classification and permissible ambient temperature ranges is shown in the table below:

Temperature class	Permissible ambient temperature range
T6	-40 °C ... 60 °C
T5	-40 °C ... 70 °C
T4	-40 °C ... 80 °C

Electrical data

Signal circuit

Type of protection; Intrinsic safety
EEx ia IIC only for connection to a
certified intrinsically safe circuit

Maximum values:

U_i = 28 V

I_i = 115 mA

P_i = 1 W

L_i = negligible

C_i = 5.3 nF

The user shall be informed of these Notes in a suitable manner.

Ambient temperature

The range of use of the Model 6134-2.... P/I Converter extends in
temperature class T6 to ambient temperatures from -40 °C to $+60\text{ °C}$,
temperature class T5 to ambient temperatures from -40 °C to $+70\text{ °C}$,
temperatures class T4 to ambient temperatures from -40 °C to $+80\text{ °C}$.

Pneumatic working medium

the user of the apparatus shall ensure that the working medium cannot form an
explosive atmosphere, i. e. only gases may be used that are free from substances
the existence of which could lead to an explosive atmosphere (non-combustible
gases and no oxygen or gases enriched with oxygen).

(18) **Special health and safety requirements**

Satisfied by compliance with the standards specified above.

Zertifizierungsstelle Explosionsschutz
By order

Braunschweig, 6 November 2003

(Signature) (seal)

Dr. Ing. H. Wehinger
Direktor und Professor

13 Annex

13.1 Accessories

Mounting material	Order no.
Bracket for wall mounting, stainless steel (1.4301)	1400-8837 ¹⁾
Wall and pipe mounting (2" pipes)	1400-5656
Pressure gauge retrofit for field unit: Pressure gauge including lock nut	1400-8838

¹⁾ Included in the scope of delivery

13.2 After-sales service

Contact our after-sales service for support concerning service or repair work or when malfunctions or defects arise.

E-mail address

You can reach our after-sales service at aftersaleservice@samsongroup.com.

Addresses of SAMSON AG and its subsidiaries

The addresses of SAMSON AG, its subsidiaries, representatives and service facilities worldwide can be found on our website (www.samsongroup.com) or in all SAMSON product catalogs.

Required specifications

Please submit the following details:

- Order number and position number in the order
- Type designation, model number, configuration ID, serial number
- Input and output signal
- Voltage

EB 6134 EN



SAMSON AKTIENGESELLSCHAFT
Weismüllerstraße 3 · 60314 Frankfurt am Main, Germany
Phone: +49 69 4009-0 · Fax: +49 69 4009-1507
samson@samsongroup.com · www.samsongroup.com